

ST9500™ Plastic Staple® Attacher

Item # 15000™

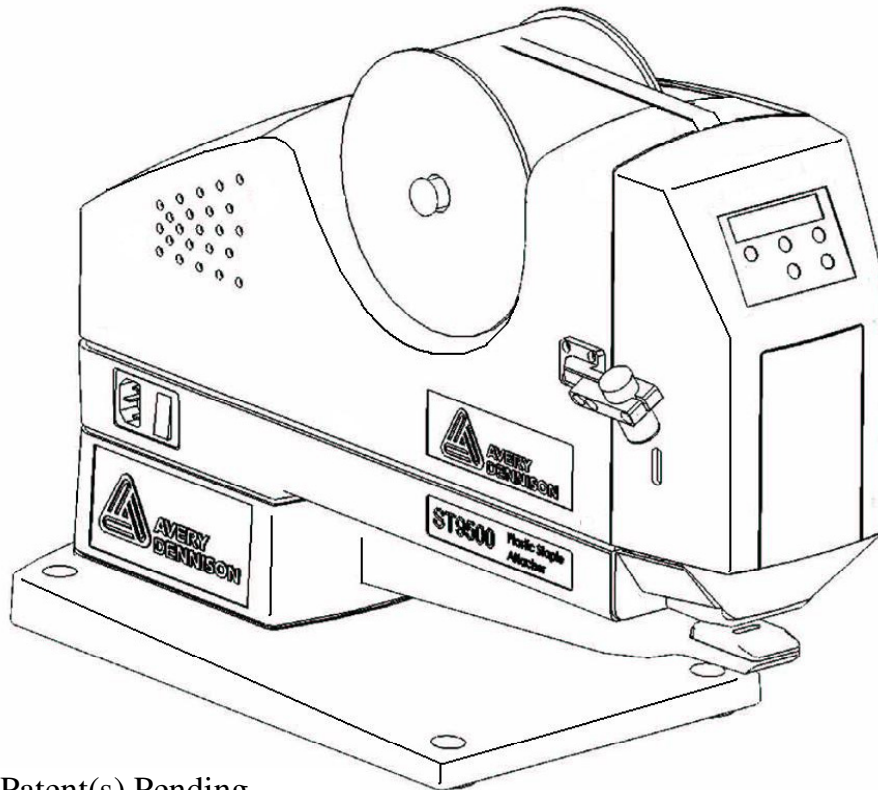

Patent(s) Pending

Operator and Service Manual®

Part No. 3-05-0100-01 Rev. 1



Fastener Division

IMPORTANT NOTICE: PLEASE READ CAREFULLY THE TERMS AND CONDITIONS OF THIS END-USER LICENSE AGREEMENT (“**AGREEMENT**”) BEFORE BREAKING THIS SEAL AND OPENING THIS PACKAGE CONTAINING THE ST9500™ PLASTIC STAPLE® ATTACHER (THE “**PRODUCT**”). AVERY DENNISON CORPORATION AND/OR ANY OF ITS SUBSIDIARIES (“**AVERY**”) IS WILLING TO LICENSE TO YOU (“**YOU**” OR “**YOUR**”) THE RIGHT TO USE THE PRODUCT ONLY ON THE CONDITION THAT YOU ACCEPT ALL OF THE TERMS AND CONDITIONS OF THIS AGREEMENT. BY OPENING THIS PACKAGE, YOU AGREE TO THE TERMS AND CONDITIONS OF THIS AGREEMENT. IF YOU DO NOT AGREE TO THESE TERMS AND CONDITIONS, PLEASE DO NOT OPEN THIS PACKAGE AND CONTACT AVERY CUSTOMER SERVICE FOR INFORMATION ON HOW TO OBTAIN A REFUND OF THE MONEY YOU PAID, IF ANY, FOR THE PRODUCT (LESS SHIPPING, HANDLING, AND ANY APPLICABLE TAXES) AT ANY TIME DURING THE NINETY (90) DAY PERIOD FOLLOWING THE DATE OF PURCHASE.

PATENT AND COPYRIGHT NOTICE: THE PRODUCT IS COVERED BY U.S. PATENT NO. 5,433,366 (THE “**PATENT**”) AND/OR CERTAIN PATENTS APPLIED FOR. THE PRODUCT ALSO CONTAINS SOFTWARE PROTECTED BY COPYRIGHT.

1. License. Subject to the terms and conditions of this Agreement, Avery grants to You a limited, personal, non-exclusive license to use the Product.
2. NOTICE--Third Party Fasteners. The Product was designed to operate with original Avery plastic fasteners. Use of third-party plastic fasteners may result in Product performance problems and/or quality risks in resulting byproducts. Accordingly, unless otherwise authorized by Avery in writing, THE LIMITED WARRANTY OFFERED IN SECTION 3 BELOW WILL NOT APPLY TO THE EXTENT THAT YOU USE THE PRODUCT WITH THIRD-PARTY FASTENERS.
3. Limited Warranty. Avery warrants that the Product will be free from defects in material and workmanship for a period of ninety (90) days (or the period stated on the specific product information literature in effect at time of delivery, if longer) after the date of shipment. It is expressly understood and agreed that Avery's sole obligation and Your exclusive remedy under this warranty, under any other warranty (if applicable), express or implied, or otherwise, shall be limited to, at Avery's discretion: (i) the replacement of the defective Product, at no additional cost to you; (ii) the repair of the defective Product, which repair will be made at Avery's own facility or at the location of the Product, at no additional cost to You; or (iii) if Avery determines that replacement or repair is not commercially practical, a reasonable credit in light of the defect in the Product, which credit shall in no event exceed the purchase price You paid for the Product.
4. Limitation of Liability. SOME STATES AND COUNTRIES DO NOT ALLOW THE LIMITATION OR EXCLUSION OF LIABILITY FOR INCIDENTAL OR CONSEQUENTIAL DAMAGES, SO THE LIMITATIONS OR EXCLUSIONS SET FORTH BELOW MAY NOT APPLY TO YOU.

TO THE MAXIMUM EXTENT PERMITTED BY APPLICABLE LAW AND REGARDLESS OF WHETHER ANY REMEDY SET FORTH HEREIN FAILS OF ITS ESSENTIAL PURPOSE, IN NO EVENT WILL AVERY BE LIABLE TO YOU FOR ANY SPECIAL, CONSEQUENTIAL, INDIRECT, OR SIMILAR DAMAGES, INCLUDING ANY LOST PROFITS, ARISING OUT OF THE USE OR INABILITY TO USE THE PRODUCT, EVEN IF AVERY HAS BEEN ADVISED OF THE POSSIBILITY OF SUCH DAMAGES. IN NO EVENT SHALL AVERY'S LIABILITY EXCEED THE PURCHASE PRICE PAID FOR THE PRODUCT, IF ANY.

AVERY'S AGGREGATE LIABILITY UNDER OR IN CONNECTION WITH THIS AGREEMENT SHALL BE LIMITED TO THE AMOUNT PAID FOR THE PRODUCT, IF ANY.

5. Governing Law. This Agreement shall be governed by and construed in accordance with the substantive laws in force in the State of California if You purchased the Product in the United States. This Agreement will not be governed by the conflict of law rules of any jurisdiction or the United Nations Convention on Contracts for the International Sale of Goods, the application of which is expressly excluded.

6. General Provisions. If any part of this Agreement is found void and unenforceable, it will not affect the validity of the balance of this Agreement, which shall remain valid and enforceable according to its terms. This Agreement may only be modified by a writing signed by an authorized officer of Avery. This is the entire agreement between Avery and You relating to the Product and it supersedes any prior representations, discussions, undertakings, communications or advertising relating to the Product.

This manual is copyrighted with all rights reserved and may not be copied, in part or in whole, without the written consent of Avery Dennison Corporation. Avery Dennison makes no warranty, express or implied, as to its accuracy and assumes no liability arising out of its use by others.

The descriptions and specifications contained in this manual were in effect at the time the manual was approved for printing. Avery Dennison, whose policy is one of continuous improvement, reserves the right to discontinue models at any time or change specifications or design, without notice and without incurring obligations or liability.

Copyright (c) 2008 Avery Dennison Corporation. All rights reserved. Avery Dennison and all other Avery Dennison brands, product names and codes are trademarks of Avery Dennison Corporation.



Avery Dennison Corporation
Fastener Division
224 Industrial Road
Fitchburg, MA 01420

Visit us on the web at
www.fastener.averydennison.com

Printed in China

Contents

Important Safety Instructions

Chapter 1 Introduction

Chapter 2 Installation

Unpacking the ST9500™	9
Mounting the ST9500™	10
Setting Up the ST9500™	11

Chapter 3 Operation

Operating the Front Panel	14
Adjusting Needle Spacing	18
Double Shot Mode and Single Shot Mode Switch	19
Loading Fasteners	20
Adjusting the Fastener Cut	22
Inserting a Fastener into a Garment	23
Inspecting the Fastener Cut	24

Chapter 4 Theory of Operation

Electric Schematic Block	26
The ST9500™ Cycle	27

Chapter 5 Parts Replacement

Removing the Enclosure	30
Replacing the Door Needle Guard	31
Replacing the Needle Guard	32
Replacing the Needles	33
Replacing the Ejector Rods	34
Replacing the Knife	35
Replacing the Feed Wheel	36
Removing the Head Assembly	38
Removing the Ejector Slide	40
Replacing the Knife Lever	41
Replacing and Aligning the Gears	42
Replacing the Circuit Board	44
Replacing the Capacitor	45
Replacing the Motor, Coupling, and Crank Arm Assembly	46

	Replacing the Crank Arm	48
	Replacing the Coupling.....	49
Chapter 6	Troubleshooting	
<hr/>		
	ST9500™ Doesn't Actuate or Actuates Abnormally.....	51
	Panel Doesn't Display or Works Abnormally.....	51
	Host Software Application Doesn't Function Properly.....	52
	Fastener Problems	52
	Ejection Problems	53
Chapter 7	Routine Maintenance and Lubrication	
<hr/>		
	Daily Maintenance	54
	Lubrication	55
Chapter 8	Parts List	57
<hr/>		
Chapter 9	Contact Information	79
<hr/>		

Important Safety Instructions

WARNING	For your safety the information in this manual must be followed to prevent personal injury or loss of life
<ul style="list-style-type: none">● The needles are extremely sharp and can cause serious injury. Keep hands and personal clothing clear of needles during operation.● Do not remove the needle guards and do not operate the machine without needle guards in place.● Disconnect power to the machine before replacing needles.● Do not attempt to remove the cover, or service or disassemble any component while the ST9500 is connected to a power source. Disconnect the power cord before attempting to replace any component.● Do not operate the ST9500 with the cover removed or make any attempt to defeat the cover interlock switch. Moving parts and shock hazard can cause serious personal injury.	

CAUTION	Improper use of lubricants can cause machine failure and/or damage to the garment.
<ul style="list-style-type: none">● Do not use any type of lubricant on the fastener path use only compressed air to clean it.● Do not use any solvents on the ST9500.	

Introduction

This manual provides all of the information required to install, operate, troubleshoot, and service the Avery Dennison ST9500™ Plastic Staple® Attacher.

The ST9500 fastens garment size, pricing, and brand-name tags to fabrics by inserting Plastic Staple® fasteners through the tag and the underlying fabric.

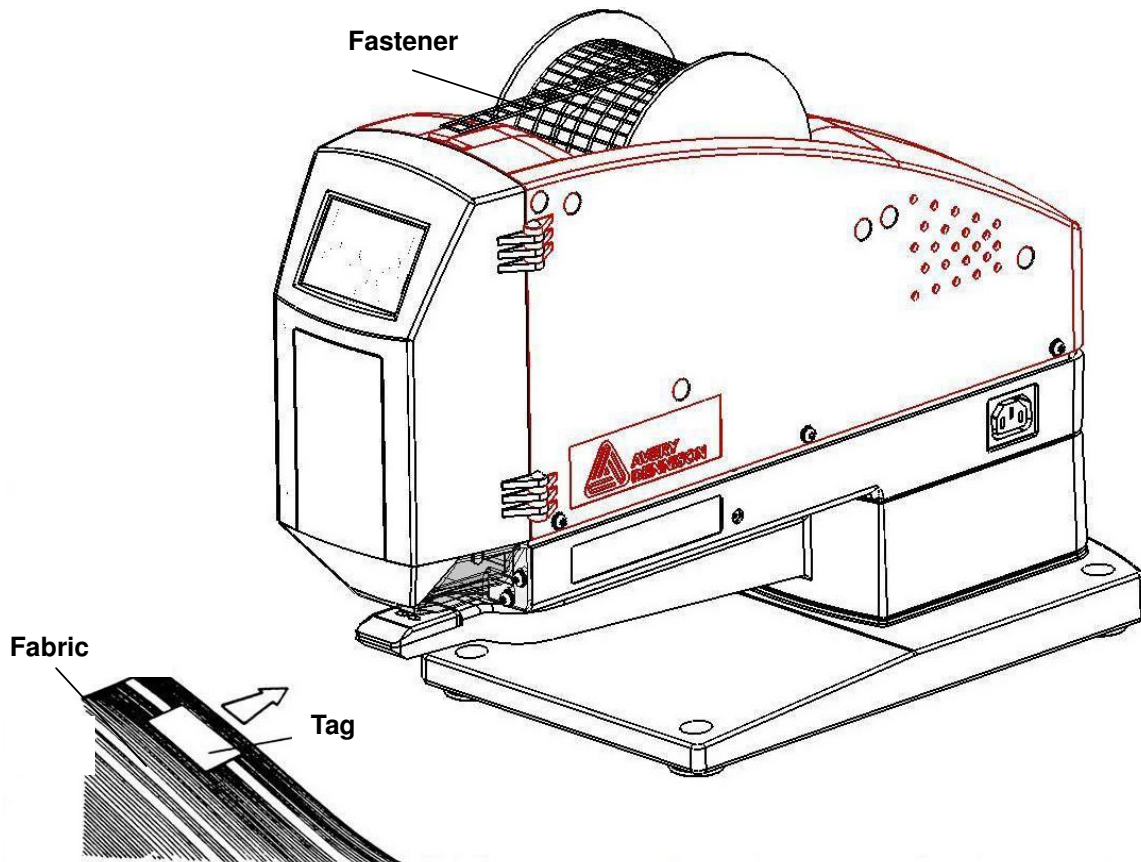
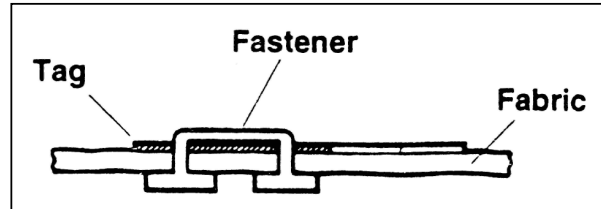

The chapter describes how to install the ST9500.

- Unpacking the ST9500
- Mounting the ST9500
- Setting up the ST9500 for operation

Unpacking the ST9500™

1. Check the contents of the shipping box. It should contain the following:
 - 1 ST9500™ Plastic Staple Attacher
 - 1 Operator and Service Manual
 - 3 Power cords
 - 1 Programming cable
2. Remove the ST9500.
3. Remove the power cords, select the appropriate cord, and discard the unneeded cords.
 - For 220/240 VAC, UL/CSA
 - For 240 VAC, CE
 - For 110 VAC, UL/CSA
4. Visually inspect the ST9500 and the shipping materials for damage.
 - If the ST9500 is damaged, notify Avery Dennison immediately.
 - If the shipping box is also damaged, notify the freight carrier as well as Avery Dennison, and save the shipping materials for the carrier to inspect.

Mounting the ST9500™

1. Decide how to mount the ST9500. The ST9500 must be bolted to a stable, heavy work surface. When shipped from the factory, it is set up as shown to the right.

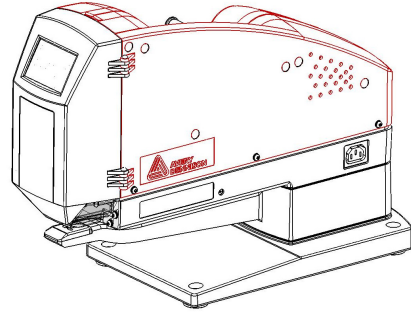

- If you require more clearance between the ST9500 and the mounting surface, you can rotate the base 180 degrees for overhanging edge of bench operation. To reverse the base, remove the four bolts from the bottom of the base, rotate the base and replace the bolts.

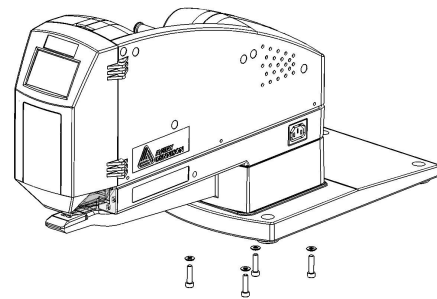

WARNING	With the base rotated, the ST9500 will not stand unsupported without tipping.
----------------	--

2. Position the ST9500 on the work surface and mark the location of the four mounting holes in the base.
3. Drill four mounting holes in the work surface for the mounting bolts.
4. Bolt the ST9500 to the work surface.

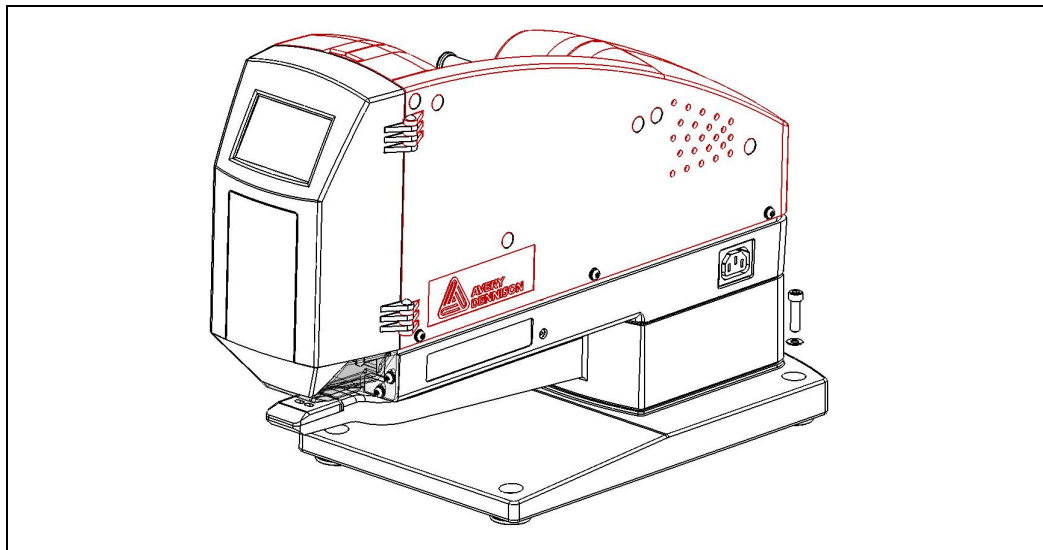

Setting Up the ST9500™

1. Open the front door.
2. Remove the shipping restraint screw.

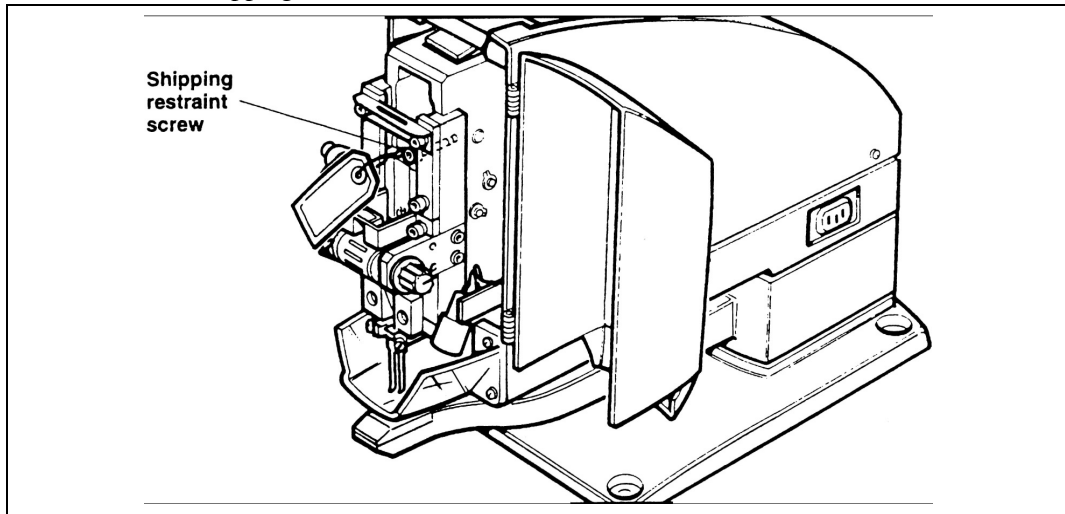

NOTE

Keep the shipping restraint screw. If you need to ship the unit, you must use this screw to lock the head in mid-cycle, as follows:

Lower the head by actuating the machine and opening the door before the machine can complete one cycle. Manually raise the head of the unit so you can thread the screw into the tapped hole and then tighten the screw.

3. Make sure the power switch is in the OFF position (0), then plug the power cord into the power cord receptacle on the ST9500.

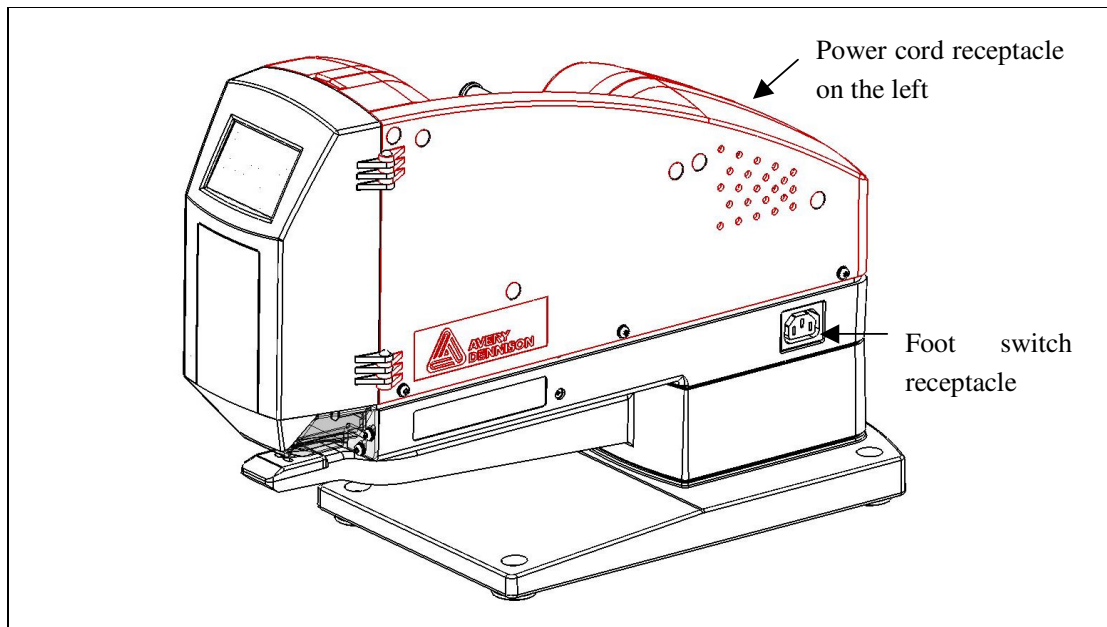

4. Plug the foot switch cord into the foot switch receptacle.

5. Connect the power cord to an electrical outlet and turn the ST9500 power switch from OFF (0) to ON (1).

The chapter explains how to operate the Avery Dennison ST9500.

- Operating the front panel
- Adjusting needle spacing
- Double shot mode and single shot mode switch
- Loading fasteners
- Adjusting the fastener cut
- Inserting a fastener into a garment
- Inspecting the fastener cut

Operating the Front Panel

1. Panel General Description

ST9500 panel consists of a digital display with blue backlight and white fore-colored letters and 5 membrane buttons for changing parameter settings. The 5 buttons are numbered as 1, 2, 3, 4 and 5, and their marks in the buttons are named as SPEED, INTERVAL, MODE, COUNT /RESET and SAVE.

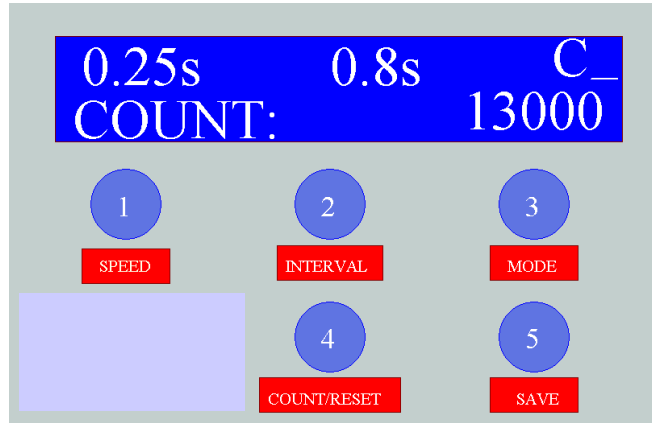

2. Display Functions: Each line displays 16 letters (or digits)

- Position I in first line (e.g. 0.25S): This indicates the cycle speed. The range is from 0.25 second/cycle to 0.6 second/cycle. Speeds are 0.25s, 0.28s, 0.30s, 0.32s, 0.35s, 0.40s, 0.45s, 0.50s, 0.55s, and 0.60s.
- Position II in first line (e.g. 0.8s): This indicates the interval time between the beginning of one cycle and the next in Continuous Cycle Mode or multiple. This value ranges from 0.0 second to 1.0 second in increments of 0.1 seconds.
- Position III in first line (e.g. C_): This indicates the Cycle Mode. The values may be 1 through 10 and C_. If the value is 1, it means the machine will run 1 cycle at a press of foot switch, and likewise, 2 for 2 cycles per press... while if the value is C_, it means the machine will keep running after you press of foot switch and stops if you press it again.
- Position in second line (e.g. Count: 13,000): This line can display the values of two different counters. One counter can be reset, while another cannot be reset but it records the accumulated cycles all through its lifetime. "COUNTER:" means the counter that can be reset and "LIFE" means the counter that cannot be reset. Both counters can count and display up to 12 digits up to 999,999,999,999 and it will begin from 0 when it is greater than this quantity.

3. Button Functions:

Membrane buttons are used to change the parameters displayed in the panel when the parameter setting function is activated.

- Button "1" ("SPEED"): This is to change the cycle speed. With each press the display will change to the next value of "... , 0.25s, 0.28s, 0.30s, 0.32s, 0.35s, 0.40s, 0.45s, 0.50s,

0.55s, 0.60s, 0.25, 0.28 ...” and it will then repeat.

- Button “2” (“INTERVAL”): This is to change the interval. With each press the display will change to the next value of “..., 0s, 0.1s, 0.2s, 0.3s, 0.4s, 0.5s, 0.6s, 0.7s, 0.8s, 0.9s, 1.0s, 0s...” which forms a loop.
- Button “3” (“MODE”): This is to change the Cycle Mode. With each press the display will change to the next value of “..., C_, 1, 2, 3, 4, 5, 6, 7, 8, 9, 10, C_, 1, 2 ...” which forms a loop.
- Button “4” (“COUNT/RESET”): This is to switch the display between the aforementioned two different counters and to reset the counter that can be reset.
 - ◆ With each “short press” (keep pressing the button less than 2 seconds) the display will switch between “CTR” and “LIFE”.
 - ◆ With each “long press” (keep pressing the button longer than 2 seconds) the counter that can be reset will be reset
- Button “5” (“SAVE”):
 - ◆ With each “short press” to save the settings you just made to the RAM in the machine, so that this setting can be activated when you power on the machine next time.
 - ◆ With each “long press”, the panel will display a password entering dialogue and you can switch the machine between Password Enable and Disable modes.

4. Password Enable and Disable Functions:

To use the password Enable and Disable function is for better management of the privileges in changing machine parameters. The machine reserves the availability to switch from Password Enabled Mode to Password Disabled Mode and vice versa. In the former mode, the user need to enter a valid password before he can change the motor parameters, then need press the button “5” (SAVE) to save it after changing the motor parameters; while in the latter mode, the user can change the parameters without any password and it can save the parameters real time.

The machine will be set to Password Disabled Mode when it is shipped from the factory.

4.1 Switch between Password Enabled Status and Password Disabled Status:

a). Long press (keep pressing over 2 seconds) the Button “5” at any time when the machine is powered on, and the display will show a indication as “XXX” for the user to enter a password. After a valid password, the machine will be switched from Password Disabled Status to Password Enabled Status or reverse.

b). When you want to enter a password, you will use the buttons described as below:

- Press “1” to change the display of the first digit of the three. With each press the first digit will change to the next value of “...0, 1, 2, 3, 4, 5, 6, 7, 8, 9, 0, 1...” and then it repeats.
- Press “2” to change the display of the second digit and pressing “3” to changes the display of the third digit.
- Press “5” as confirmation key to confirm the password you just enter.
- If the password is invalid, the display will show “XXX” again; Then please try to enter a valid password by the abovementioned procedure;
- If the password is valid, the display will show “Enable” or “Disable”; then press “1” button to switch between the two, and then press “5” to confirm.

4.2. Operations in Password Enabled Mode:

a). Press any of the three Buttons of “1”, “2” and “3” at any time in Password Enabled Status, and the display will show a indication as “XXX” for the user to enter a password. After a valid password, the user can change the Speed, Interval and Mode parameters, and then press “5” to confirm.

b). Follow the same procedure as 4.1. b) to enter password.

c). Change the parameters as described in above “3. Button Functions” In this step the settings will be activated at once after each press of the button and user may run the machine to test the settings and may change them if necessary. But in this step the settings are not saved to the Flash Memory and therefore if the power fails at this time, the settings will not be saved.

d). Press Button “5” to save the parameter settings to the flash memory and the machine will return to Normal Working Status. Note: if the Button “5” is not pressed the machine will not save the parameters or return to Normal Working Status and the user may continue to change the parameters.

e). If you need change the parameter next time, repeat operations from step “a)”to step “d)”.

4.3. Operations in Password Enabled Mode:

User can press the four buttons to change the parameters settings as described in above section 3. “Button Functions”.

4.4. Super Administrator Password:

If you forgot the password, please contact Avery Dennison.

4.5 Password Change: You may change the password by following the display instructions.

5. Panel Operation Flow Chart:

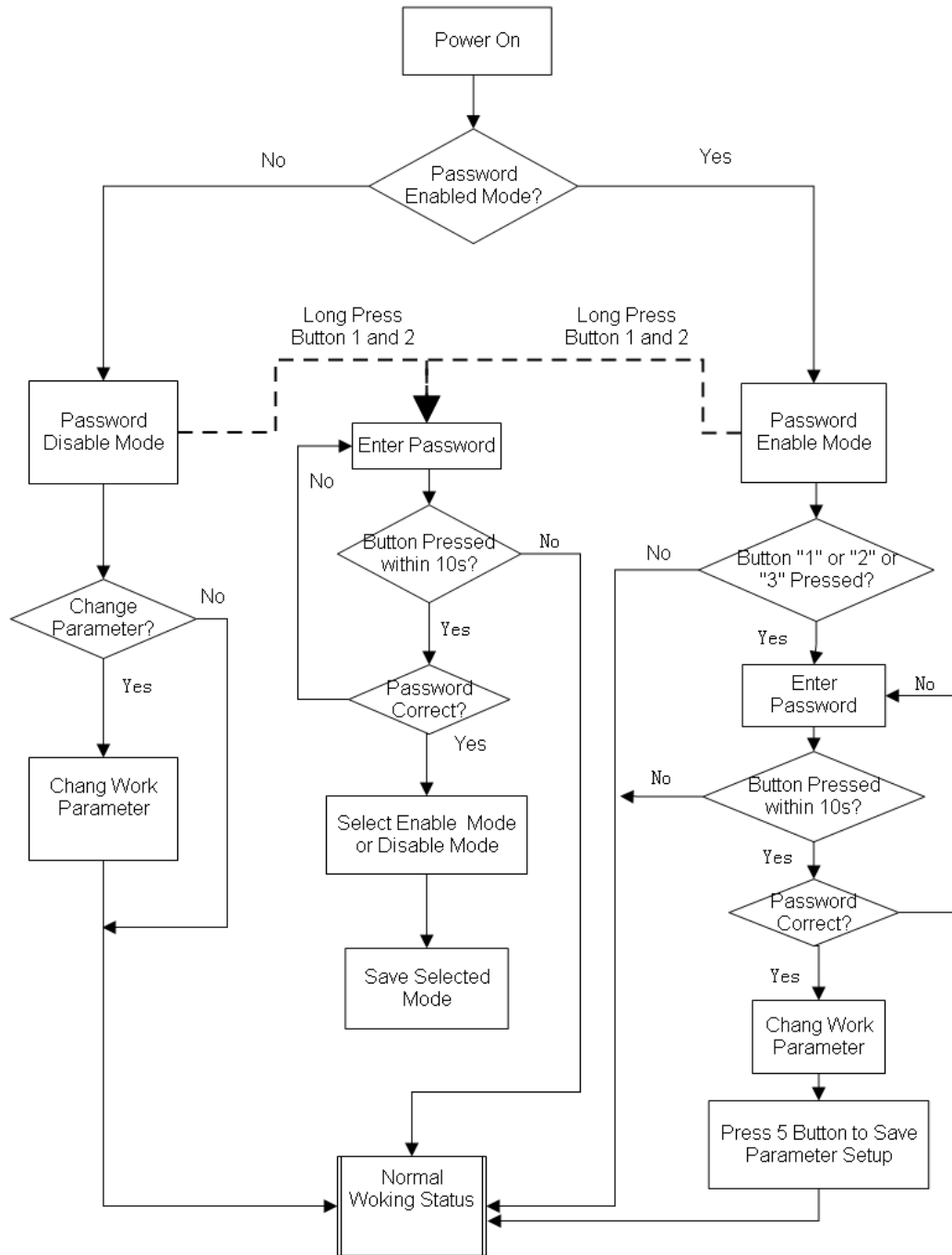

Adjusting Needle Spacing

1. Open the front door.
2. Turn the Knob and adjust the space between the two needles. When you adjust the needle spacing, please make sure that the Ejector Rods move according to the needles, if the Ejector Rods do not move then there might be some friction with the Ejector Rod guide at the top. Please use your finger to help it move if necessary.
3. The adjustable range of needle spacing is 6~12 mm, you may read the data from the scale at the plate.

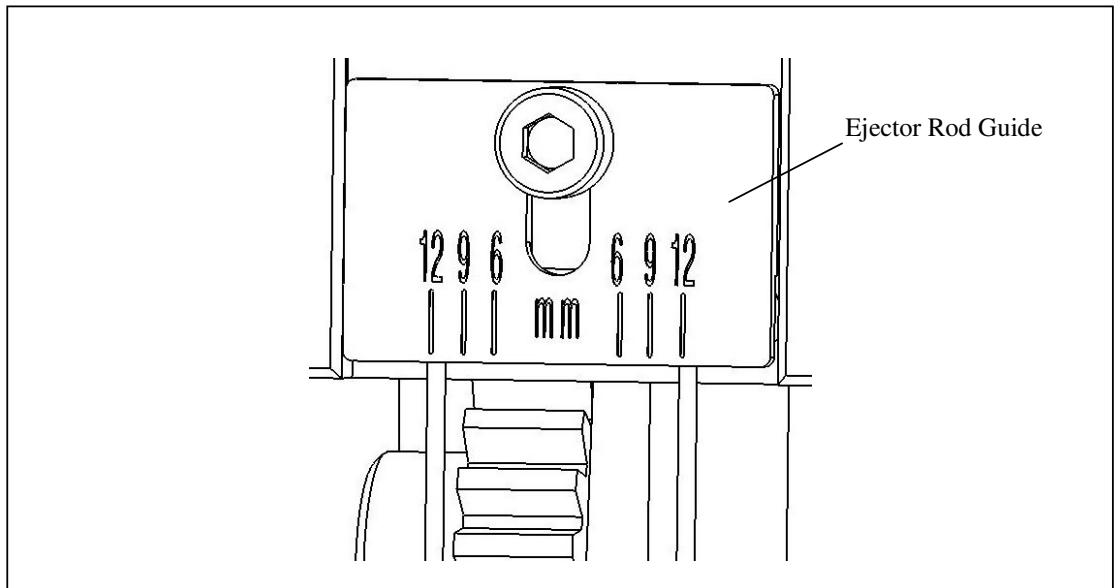
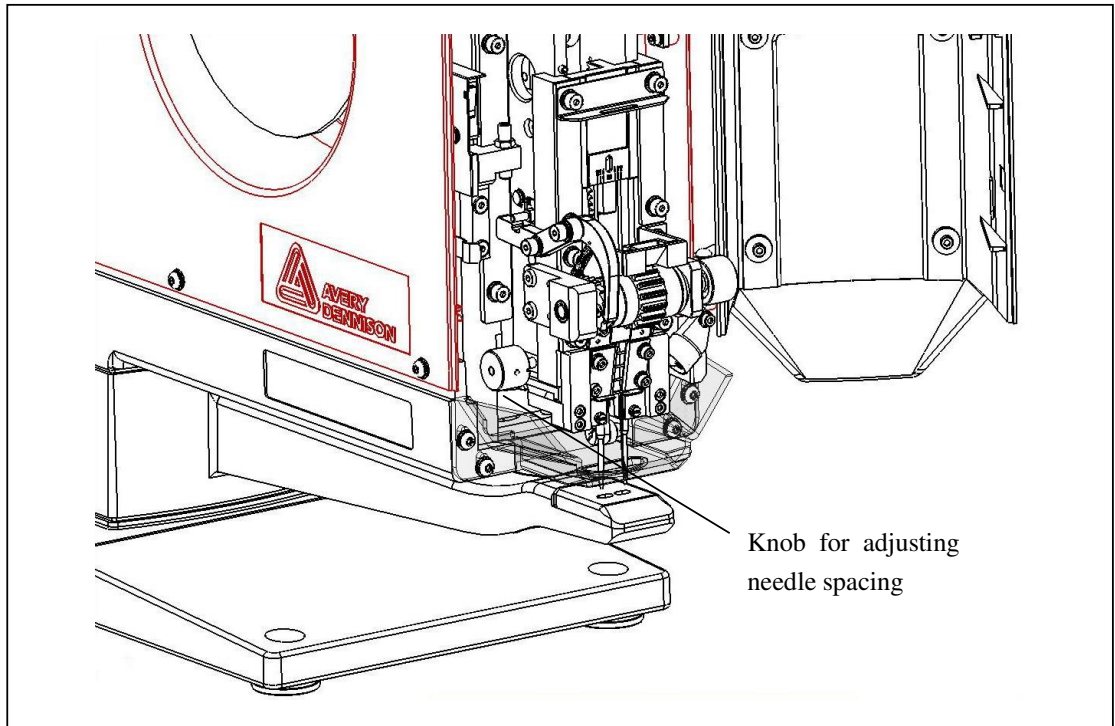

Double Shot Mode and Single Shot Mode Switch

1. Open the front door.
2. Use a screw driver to loose the Mode Switch Knob;
3. Use the Mode Switch Knob to switch the shot mode between double shot and single shot. In double shot mode, the machine feeds two pieces of staples at a cycle, while in single shot mode the machine feeds one piece of staple at a cycle.
4. When the arrow in the picture below points to "I" the machine works on single shot mode, while the arrow points to "II" the machine works on double shot mode.
5. Tighten the screw of Mode Switch Knob after switching.

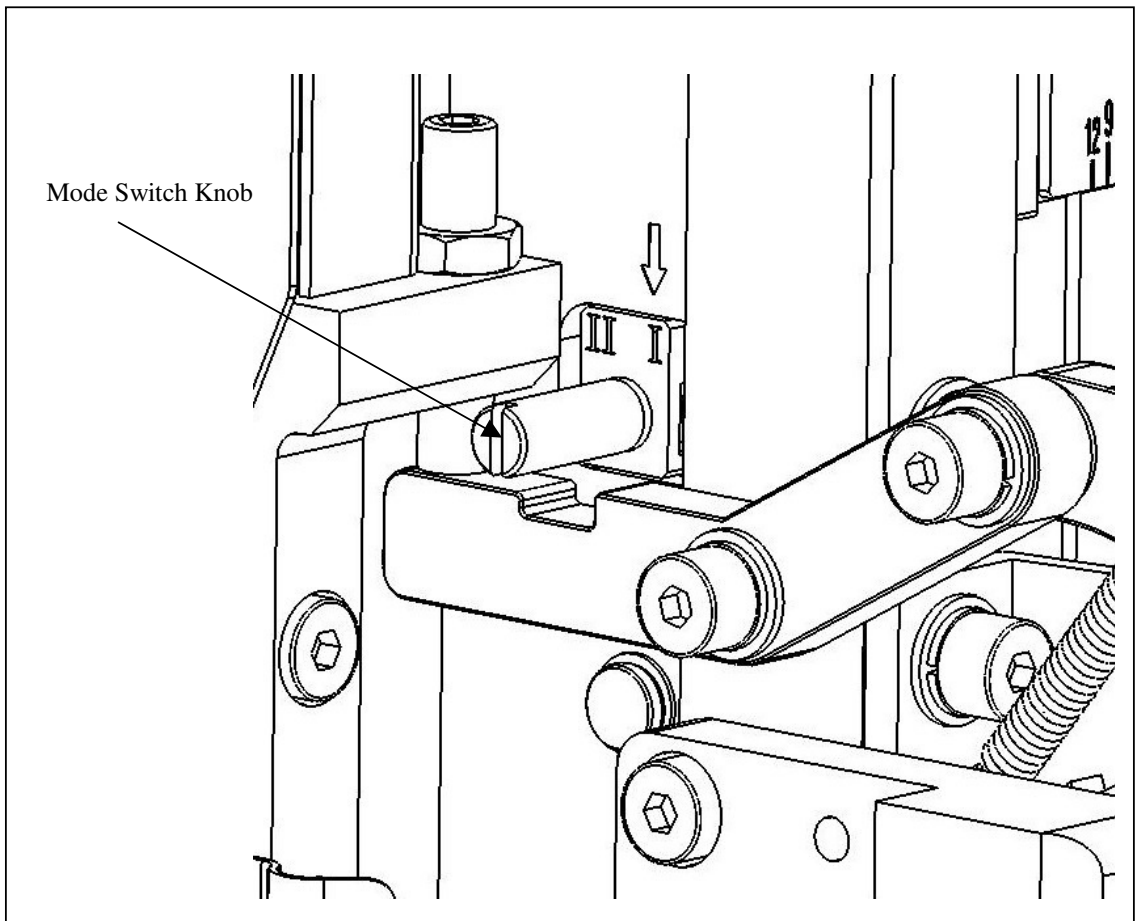

Loading Fasteners

1. Turn the power switch to OFF (0).
2. Open the front door of the ST9500.
3. Place a reel of fasteners on the reel support with the fasteners coming off the top of the reel. Check that the reel rotates freely.

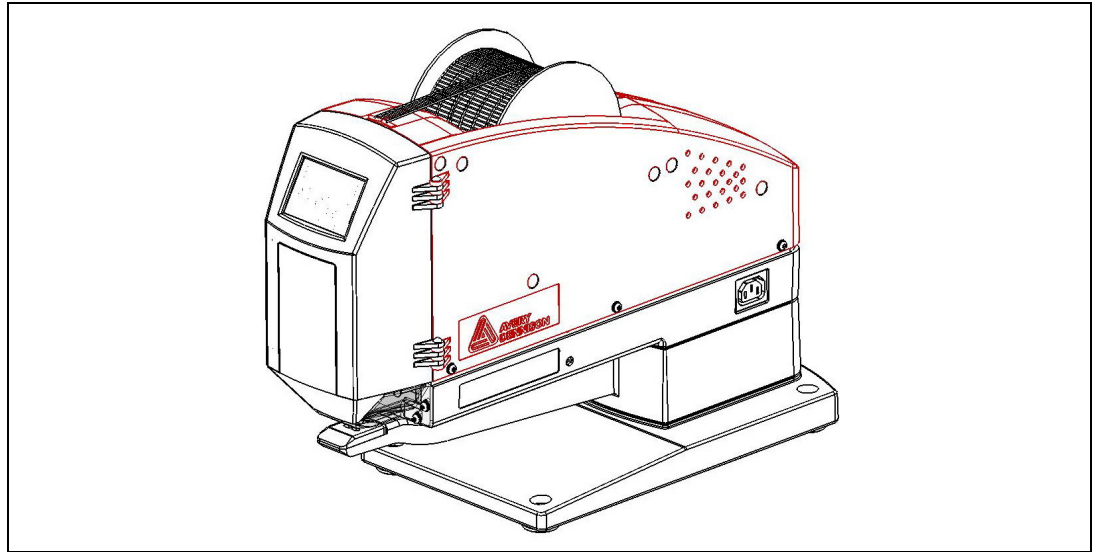

4. Cut the end of fasteners half way between two rungs.

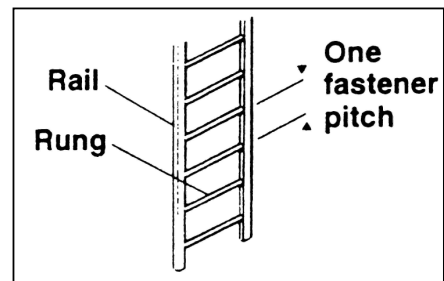

5. Feed the fasteners through the upper slot on the front of the ST9500 (refer to the fastener feed diagram inside the front door, if necessary).

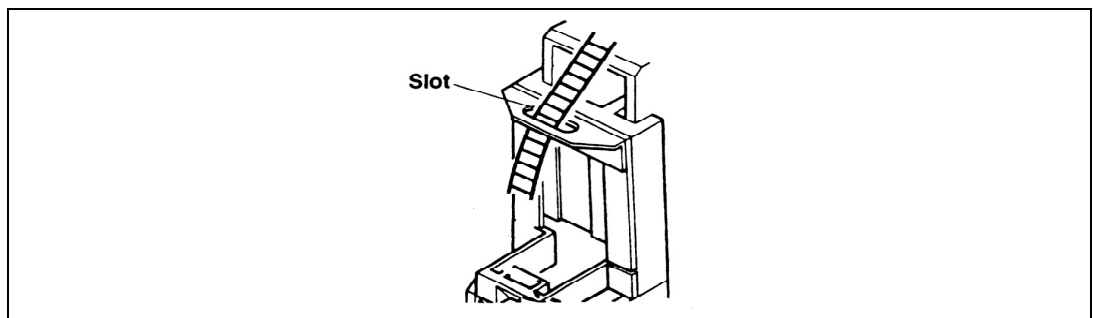

6. Feed the fasteners into the plastic guide above the feed wheel.

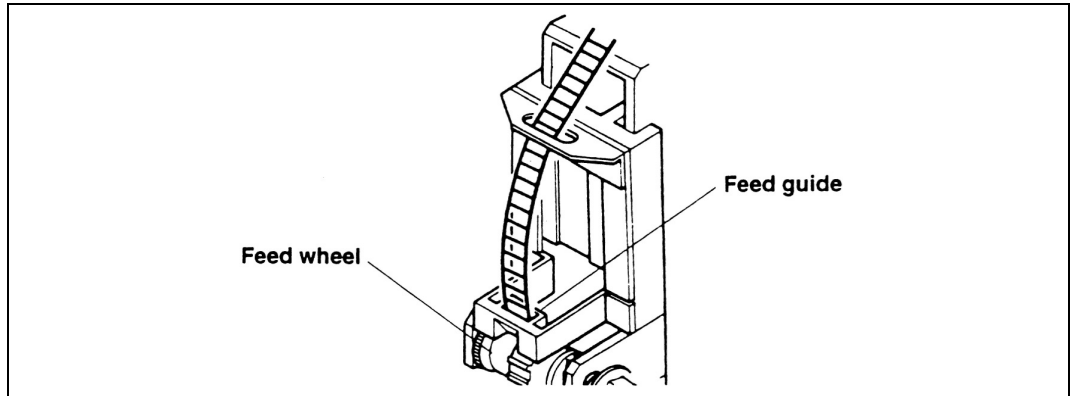

7. Feed the fasteners down behind the feed wheel.
8. Turn the feed knob clockwise to advance the fasteners down through the knife block.

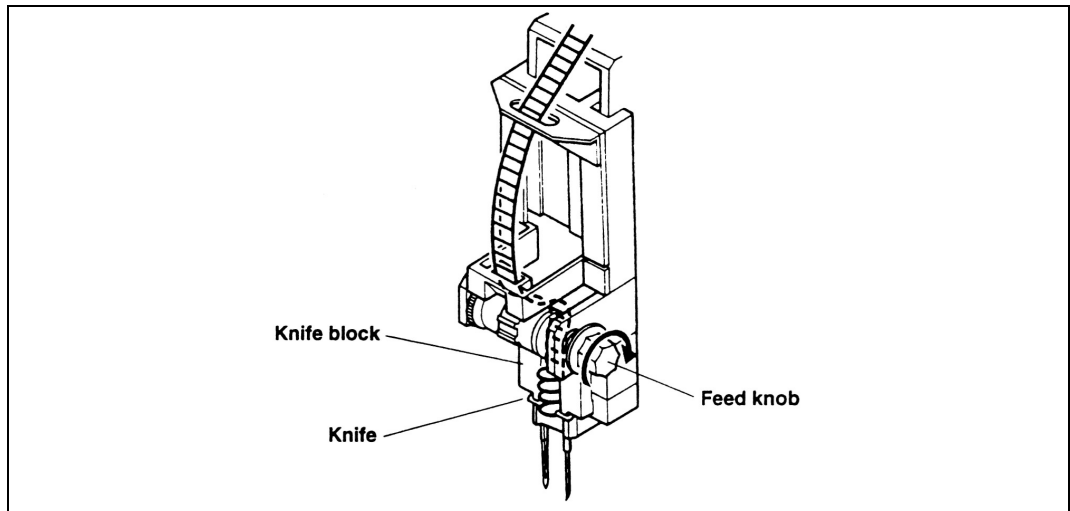

9. Continue turning the feed knob until the knife is centered between two fastener rungs.

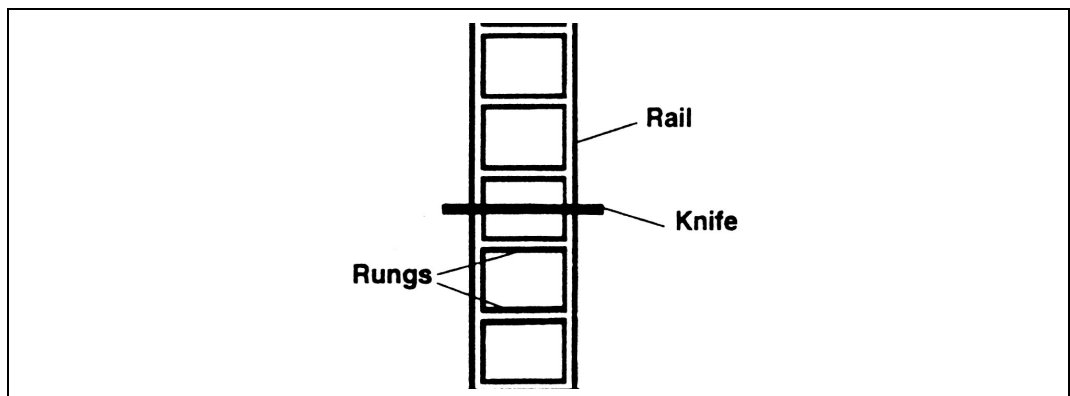

Adjusting the Fastener Cut

If the knife is not centered between two fastener rungs, you must adjust the fasteners position.

1. Loose the nut, screw in or out to adjust the adjusting screw. Then lock the nut after adjustment.
2. Feed the fasteners and cut, and check if the fasteners are cut properly now at midway.
3. Repeat above step 1 and 2 until the fasteners are cut at the correct position.

Note: Please remember to lock the nut after ultimately adjusted the fastener cutting. As this machine is using a Non-adjust Feeding System, you do not need to adjust the fastener cutting every time.

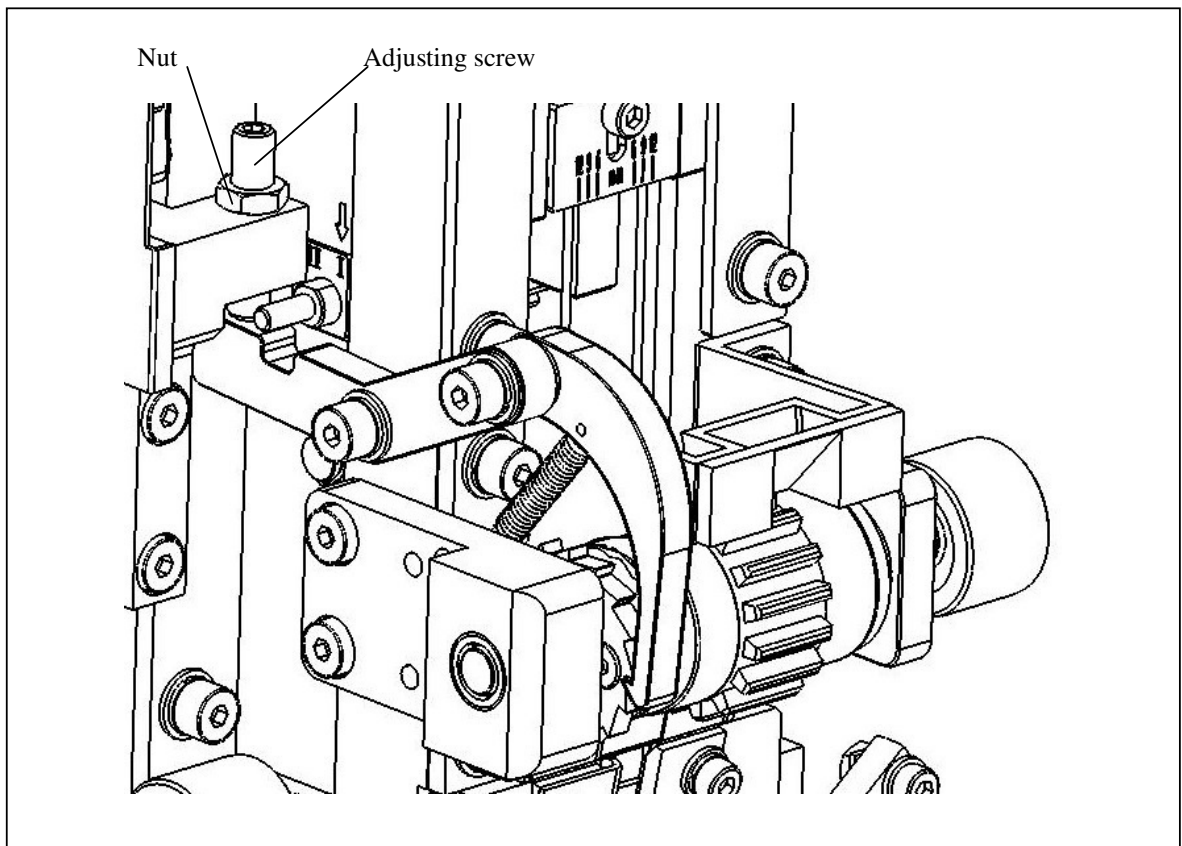

Inserting a Fastener into a Garment

1. Place the garment and tag between the reactor plate and the needle guard.

! WARNING	The needles are extremely sharp and may cause serious injury. Keep hands and personal clothing clear of the needles during operation. Do not remove the needle guards and do not operate the machine without needle guards in place. Disconnect power to the machine before replacing needles.
------------------	---

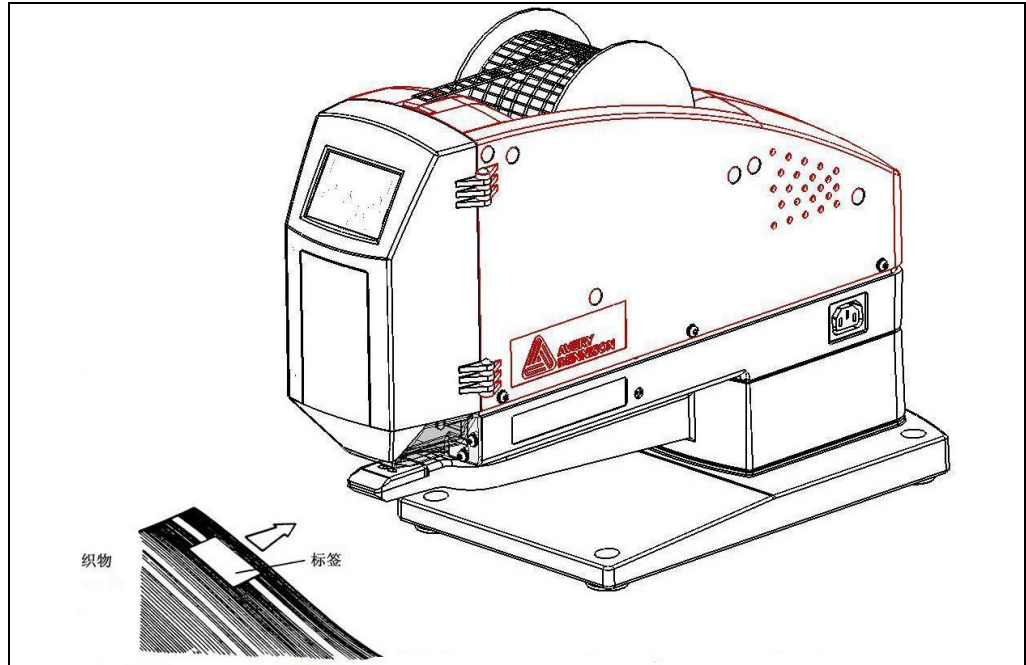

2. Press the foot pedal to actuate the machine.

NOTE | The front door is equipped with an electrical interlock switch that disables power of motor when the door is opened. The door must be completely closed to operate the ST9500.

3. Reposition the garment for the next fastener and press the foot pedal.
4. Continue the process until the garment is fully tagged.

Inspecting the Fastener Cut

1. Inspect the fastener to see if it is inserted into the fabric correctly.

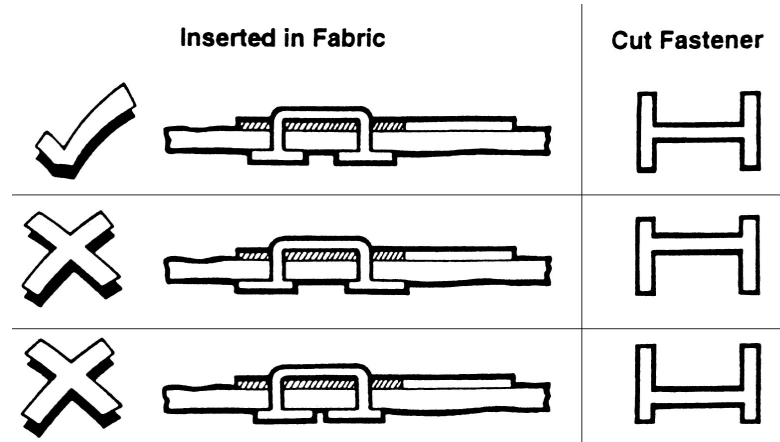

2. Adjust the fastener cut if necessary (see page 19).

Theory of Operation

This chapter describes the operating principles of the ST9500.

You should read this chapter if you are responsible for troubleshooting and repairing the ST9500.

Electric Schematic Block

ST9500 electric system consists of Power, MCU Control, Motor Driver, LCD Display and Operation Panel, Footswitch and Sensors, LED lighting etc.

ST9500 switching power provides the power supply for all the machine, the switching powers operates on wide range of AC voltage 110 ~ 240VAC, 50/60Hz, you do not need any transformer if the industrial power supply is within the range of 110 ~ 240VAC, 50/60Hz.

MCU controller consists of three MCU modules integrated in one control board. Among the three, one MCU is to communicate with Motor Driver so as to control the cycle speed, rotating direction and stroke of the stepping motor. The MCU is also used for panel display. The other two MCU are used for network communication and control.

ST9500 Motor Driver receives instruction from MCU controller and drives the stepping motor to run accordingly. LCD display is used to show to the user the current status of the machine. The operation panel is used to change and save the settings for cycle speed, interval, mode etc. as mentioned in Chapter 3 Operating the Front Panel. Footswitch is used to give manual instruction so as to actuate the motor to cycle or to stops it. Sensors are used for the machine to detect the top (home) position when the head moves, MCU gets signals from these sensors and can judge if there's a jamming occurs. LED lighting is used for providing light to the operator.

The electric schematic block is shown below:

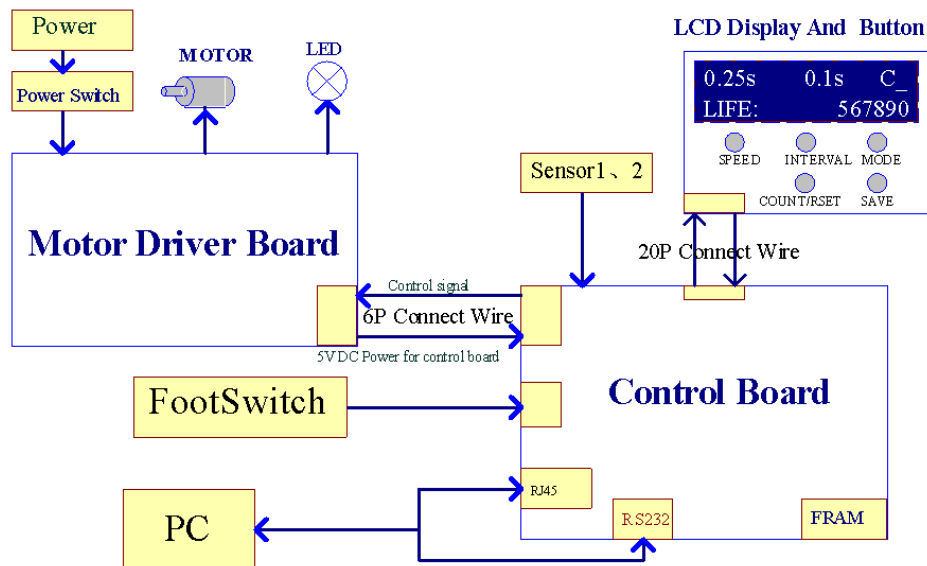

The ST9500™ Cycle

The ST9500 inserts one or two Plastic Staple® fastener(s) each cycle. Typically, the fastener attaches a ticket to a piece of fabric.

How many cycles per press of the footswitch would the motor run? It depends on the settings of the cycle mode. Please refer to Chapter 3 Operating the Front Panel.

The following describes one cycle.

- Open the front door and adjust the needle space and shot mode (single shot or double shot) before powering on the machine. Adjust the settings (cycle speed, interval, cycle mode etc) through the front panel.
- When the operator presses the footswitch, MCU receives a signal as an instruction to run the motor, then MCU analyzes the settings that is saved in the RAM, and sends signals accordingly to the motor driver, and motor driver drives the motor to run according to the settings.
- The stepper motor is linked to Head by a Crank, when the motors runs a circle, the Head runs a cycle.
- As the head starts down , a cam inside the head pushes a lever which moves the knife, cutting the fastener.
- As the head moves down , gears inside the head drive the ejector rods down faster than the rest of the head. The ejector rods drive a fastener out the needles and through the garment.

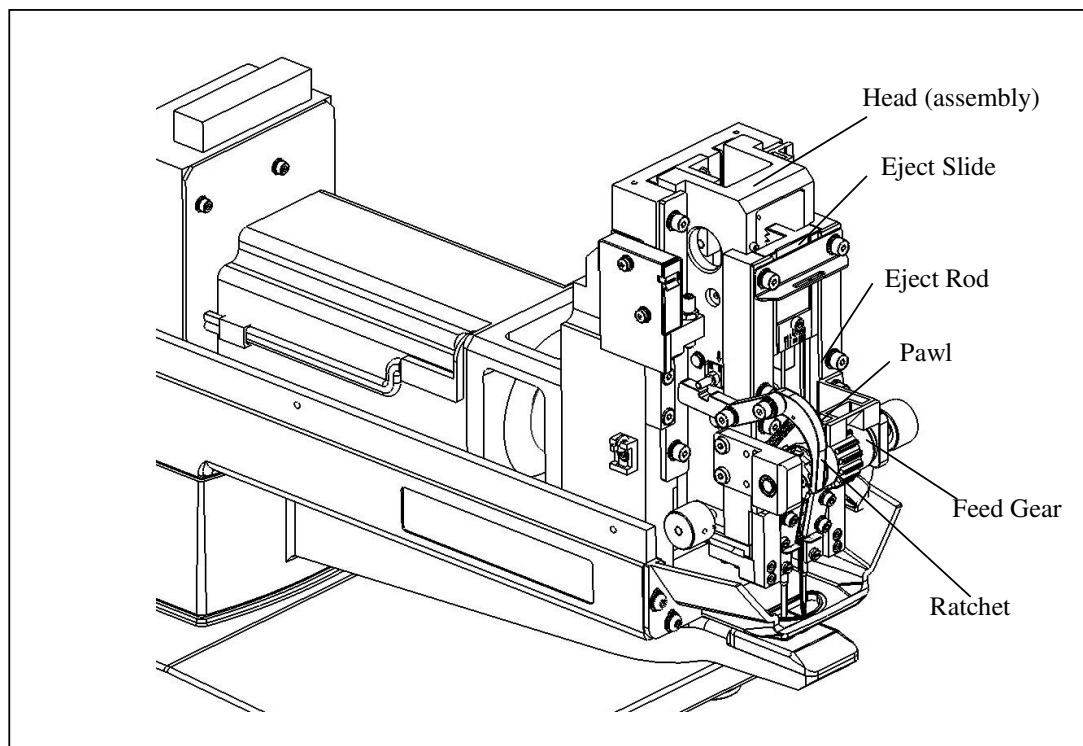

After the Head goes all the way down to the bottom, it turns to go up; when the head comes up , the feed pawl engages the ratchet on the feed wheel, advancing one or two (depends on setting) new fastener(s) into the cut position.

When the Head continues to move up all the way to the top, it activates the Sensor to give a signal to the MCU, MCU judges whether the motor should stop or continue to run another cycle according to the settings.

Parts Replacement

This chapter describes how to remove, replace, and adjust the field serviceable components in the ST9500.

Required Tools

- Small and medium flat blade screwdrivers
- Small Phillips-head screwdriver
- Pair of needle-nosed pliers
- Set of metric ball-end Allen wrenches
- C-ring pliers
- Small hammer
- Small punch
- 8mm open end wrench

Operational Check

NOTE | After repair or reassembly, always perform the following operational check.

1. Replace the ST9500 enclosure and needle guard.

! WARNING	Do not operate the machine without the enclosure and needle guard. Needles and moving parts cause serious personal injury.
------------------	---

2. Make sure the Power Switch is OFF (0) and plug in the power cord. The ST9500 should not cycle.
3. Turn the Power Switch ON (1). Check that motor is running.
4. Press the foot switch. The ST9500 should cycle once and then stop.
5. Load fasteners and test for correct fastener cut and insertion.

Removing the Enclosure

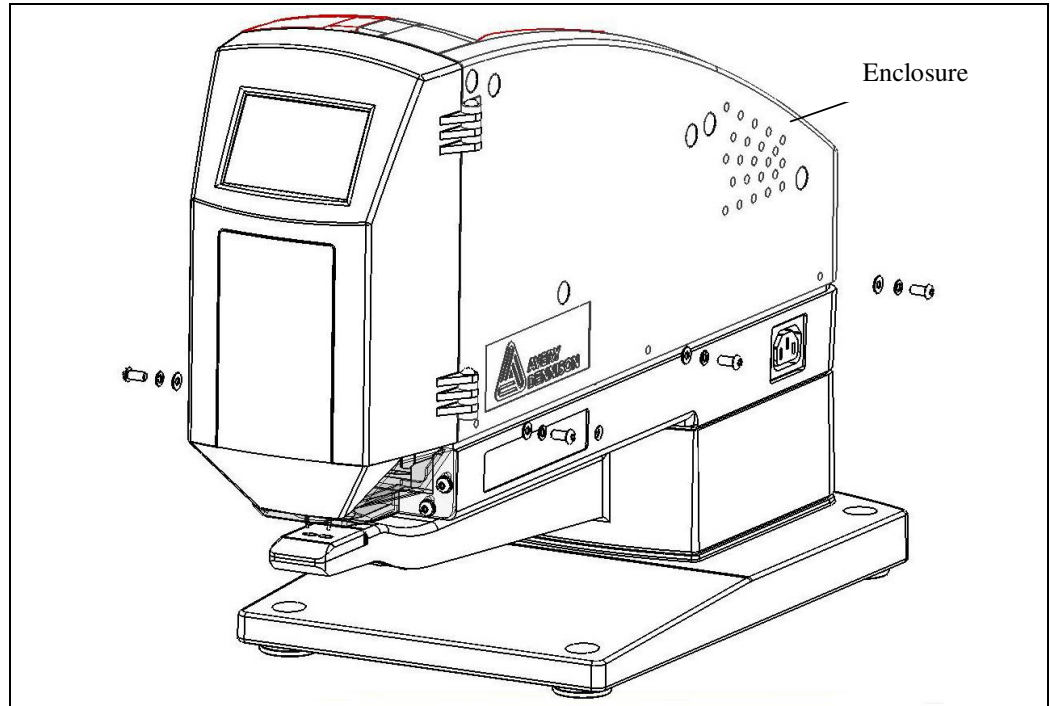

! WARNING

Do not attempt to remove the enclosure, or service or disassemble any component while the ST9500 is connected to a power source. Disconnect the power cord before attempting to replace any components.

! WARNING

Do not operate the ST9500 with the enclosure removed or make any attempt to defeat the enclosure or interlock switch. Moving parts and shock hazard may cause serious personal injury.

1. Unplug the unit.
2. Remove the fastener reel.
3. Remove the fastener reel holder.
4. Remove the four screws holding the enclosure to the frame.
5. Open the front door.
6. Slide the enclosure to the rear and remove.

Replacing the Door Needle Guard

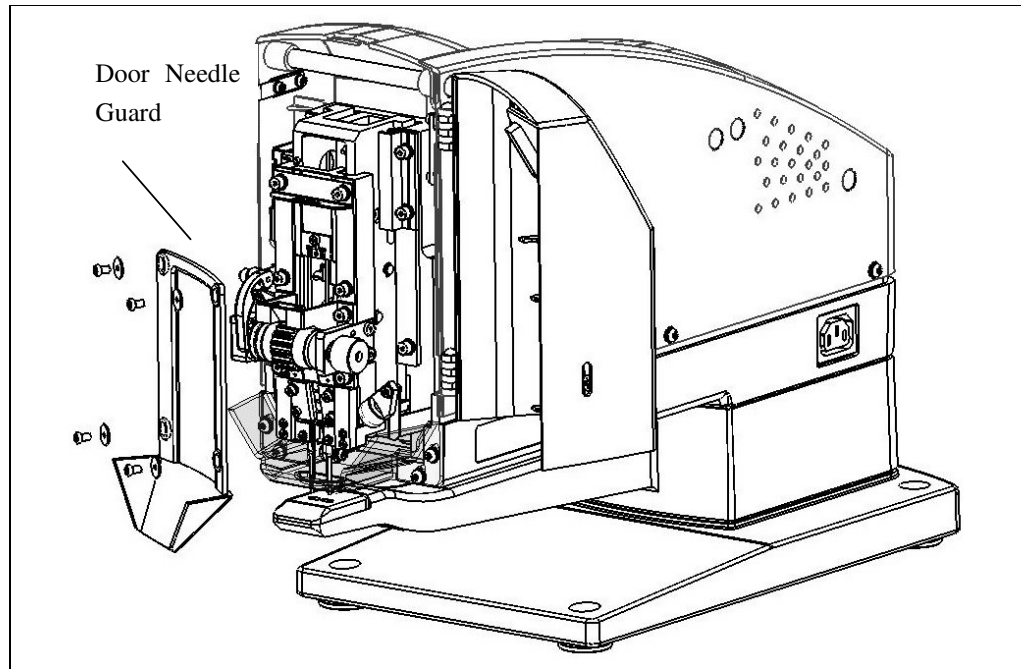

Disassembly

1. Open the front door.
2. Remove the four screws holding the door needle guard.
3. Remove the door needle guard.

! WARNING	Do not operate the machine with the needle guards removed. Needles and moving parts may cause serious personal injury.
------------------	---

Assembly

1. Position the door needle guard in the front door.
2. Insert and tighten the four screws.

Replacing the Needle Guard

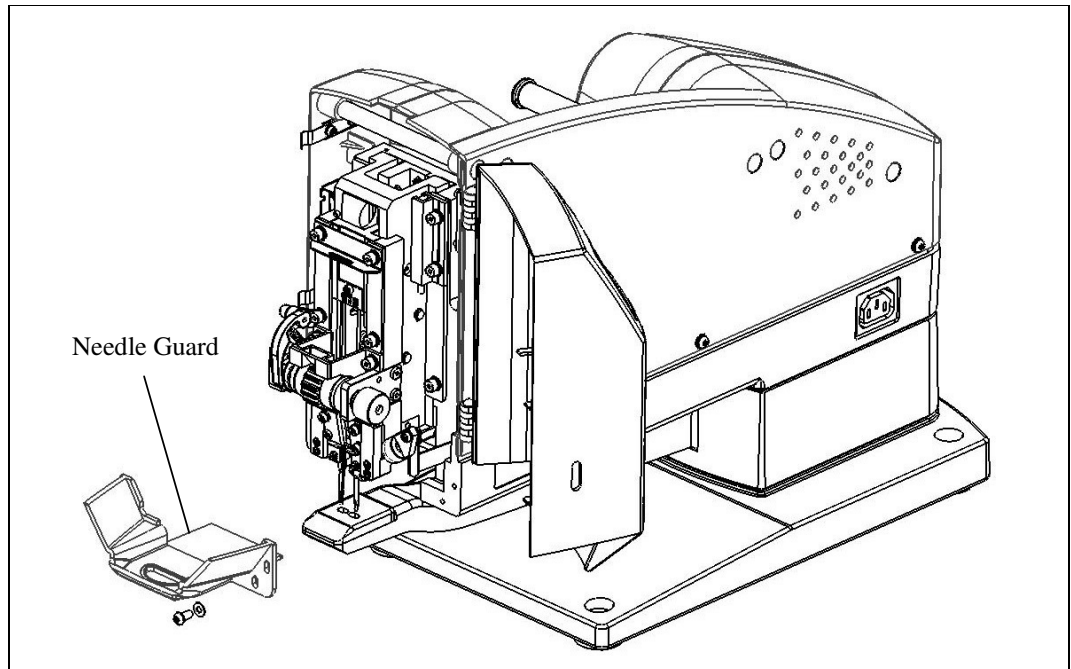

Disassembly

1. Open the front door.
2. Remove the four screws holding the needle guard.
3. Remove the needle guard.

! WARNING	Do not operate the machine with the needle guards removed. Needles and moving parts may cause serious personal injury.
------------------	---

Assembly

1. Position the needle guard.
2. Insert and tighten the four screws.

Replacing the Needles

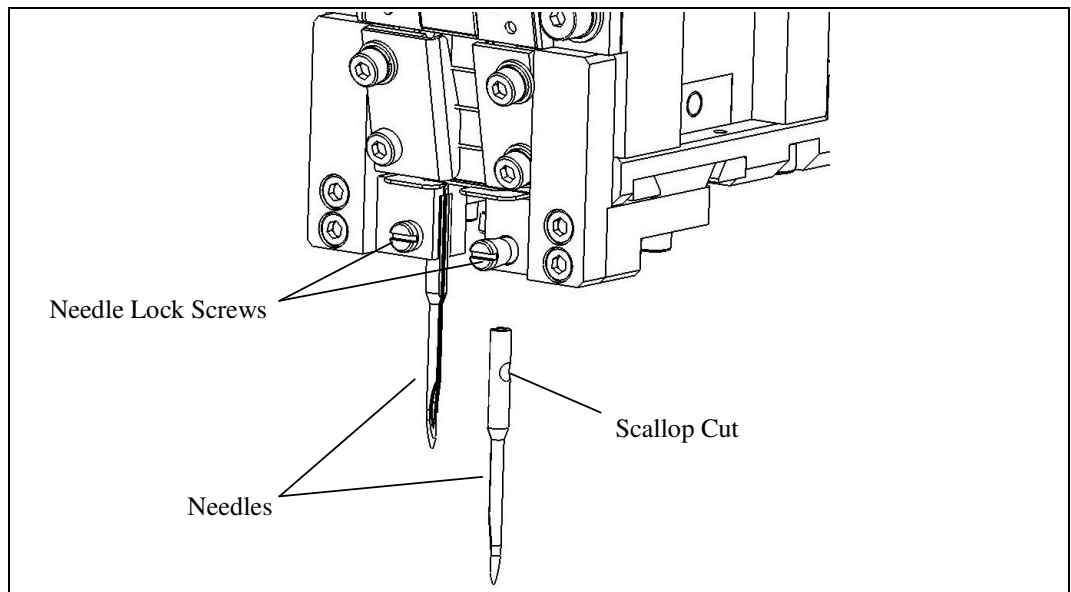

Disassembly

! WARNING

Needles are extremely sharp and can puncture skin with a minimal amount of pressure. Use extreme care when handling.

1. Unplug the unit.
2. Open the front door.
3. Remove the needle lock screw.
4. Remove the needle.

Assembly

1. Insert the needle, with the scalloped cut in the needle facing the needle lock screw.
2. Insert the needle lock screw. (If necessary, rotate the needle so the screw fits into the scalloped cut in the needle.)
3. Tighten the screw.

NOTE

The screw lock is designed to prevent squeezing of the hollow needle by the needle lock screw. After the needle lock screw is tightened, the needle may still appear to be loose. This is a normal condition and will not adversely affect fastener insertion.

Replacing the Ejector Rods

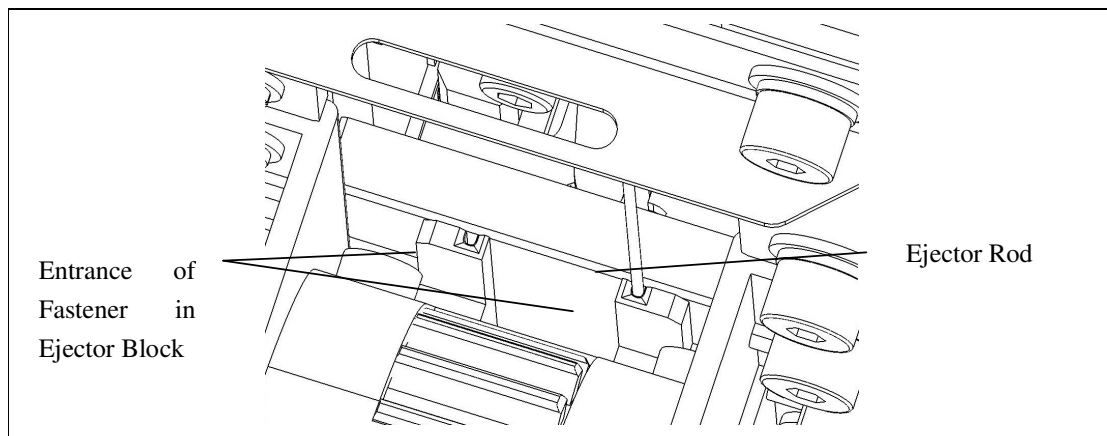
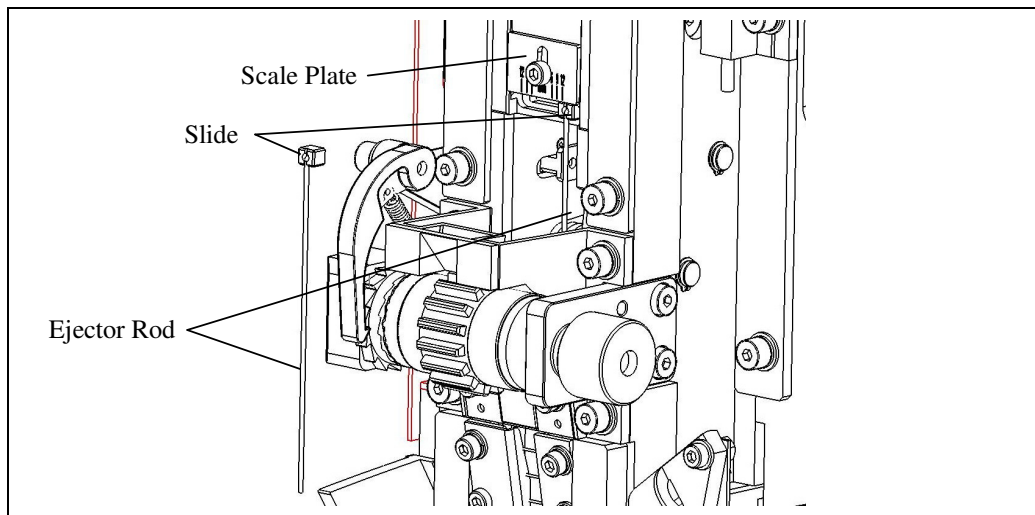

Disassembly

1. Unplug the unit.
2. Open the front door.
3. Loosen the screw holding the scale plate for access to the black ejector slide, move the scale plate up and tighten the screw.
4. Remove the defective Eject Rod together with the black ejector slide.

Assembly

1. Insert the bottom of the ejector rod into the hole in the eject block.
2. Insert the top of the ejector rod into the hole and channel on the ejector slide.
3. Repeat steps 1 and 2 for the second ejector rod.
4. Loosen the screw and recover the scale plate.
5. Tighten the screw.

Replacing the Knife

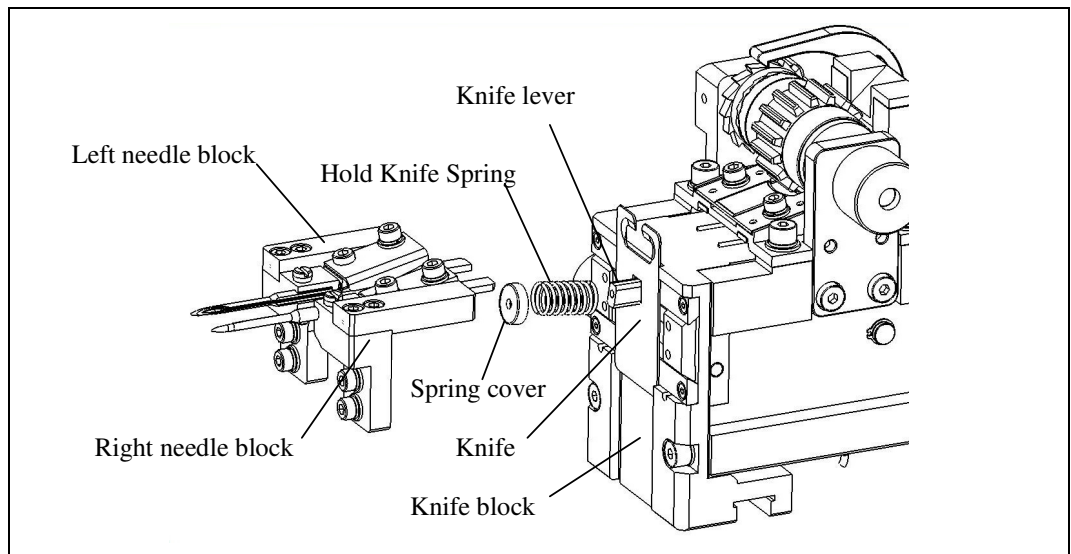

Disassembly

1. Unplug the unit.
2. Open the front door.
3. Remove the needle guard (see page 29).
4. Remove the tighten screws on the right and left needle blocks, then push the knife lever so as to remove the right and left needle blocks.
5. Remove the spring cover on the bottom of the knife spring and take out the washer and spring.
6. Remove the knife.

Assembly

1. Orient the knife with the flat side facing up.
2. Position the square hole in the knife over the square projection that drives the knife.
3. Position the knife spring over the square projection of knife lever.
4. Mount the spring cover and tighten it.
5. Check that the knife moves back and forth easily and is seated squarely in the needle holder block.
6. Make sure the needle holder is seated squarely in the needle holder block.
7. Mount the right and left needle blocks.
8. Double check to make sure the knife moves in and out freely.

Replacing the Feed Wheel

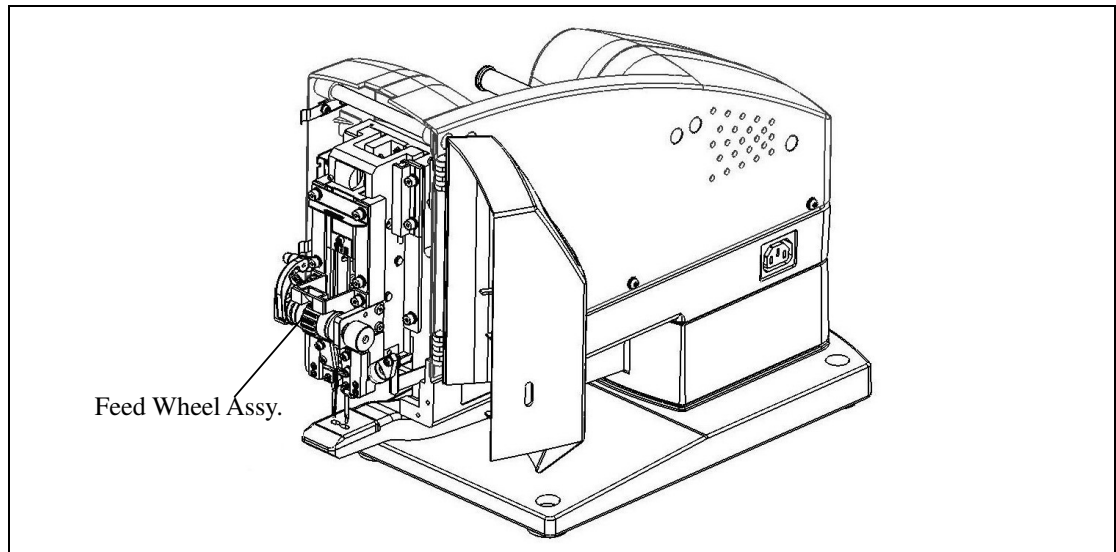

Disassembly

1. Unplug the unit.
2. Disconnect the pawl spring.

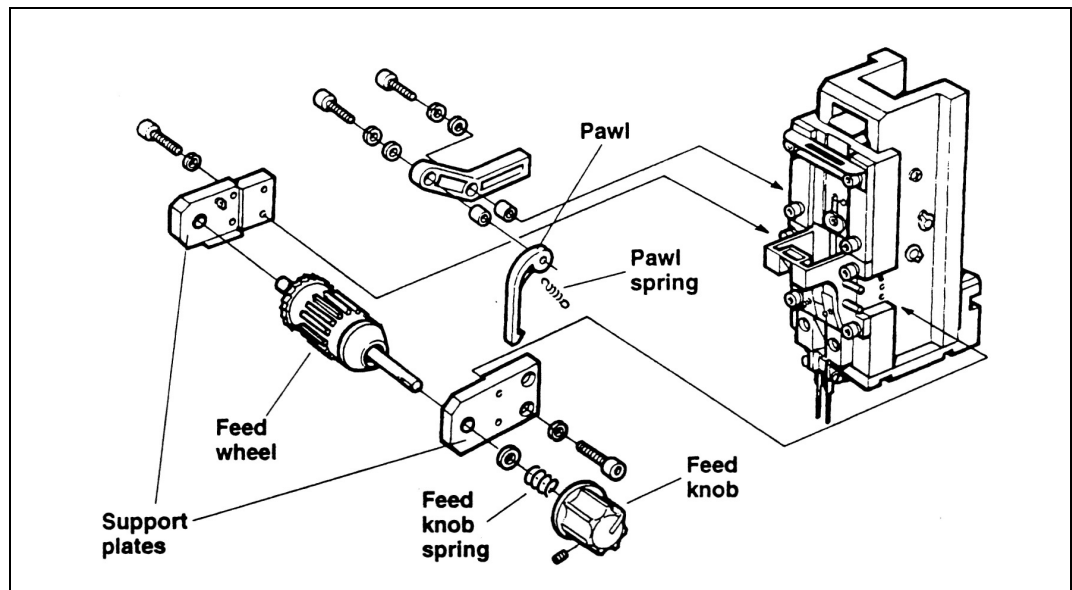

3. Remove the two screws holding the left support plate and then remove the plate.
4. Remove the two screws holding the right support plate and then remove the plate.
5. Loosen the setscrew on the feed knob and then remove the knob and spring.
6. Remove the right support plate from the feed wheel shaft.

Assembly

1. Slide the right support plate over the feed wheel shaft. (Countersunk holes on the plate face out.)
2. Replace the feed knob spring and tighten the setscrew.
3. Reattach the right support plate to the head.
4. Reattach the left support plate.
5. Reattach the pawl spring.

Removing the Head Assembly

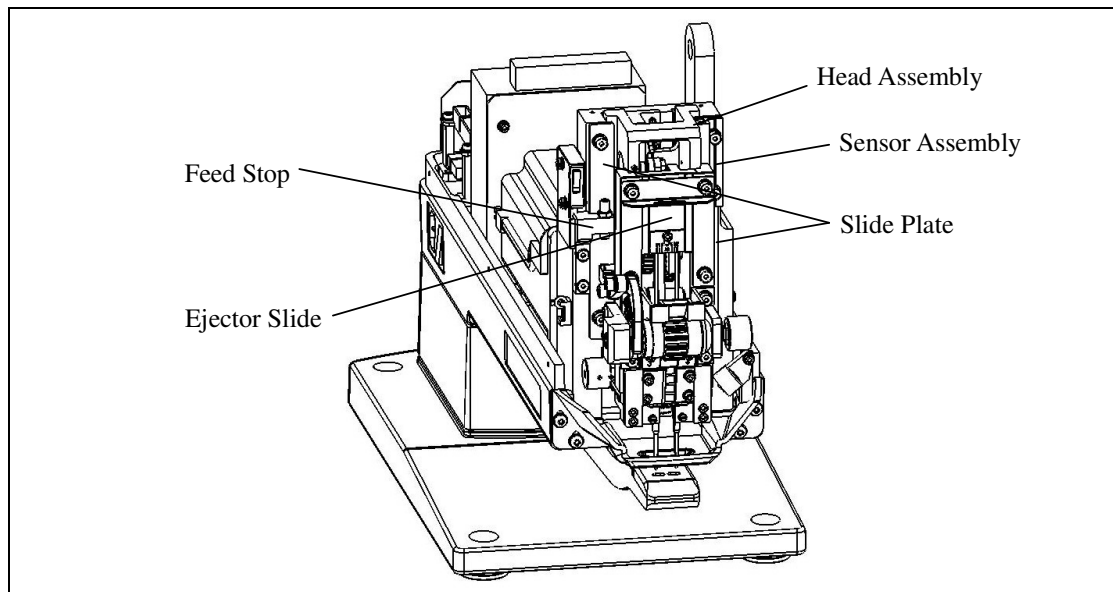

Disassembly

1. Unplug the unit.
2. Remove the reel support and the enclosure.
3. Remove the screw on the Feed Stop, and remove the Feed Stop.
4. Remove the screw on the Sensor assembly and remove the Sensor assembly.
5. Remove the two screws on each Slide Plate and then remove the Slide Plates.
6. Remove the Head Assembly.

Assembly

1. Place the crank bushing in the middle of the horizontal track on the back of the head.
2. Rotate the crank arm so the drive pin is at top dead center.

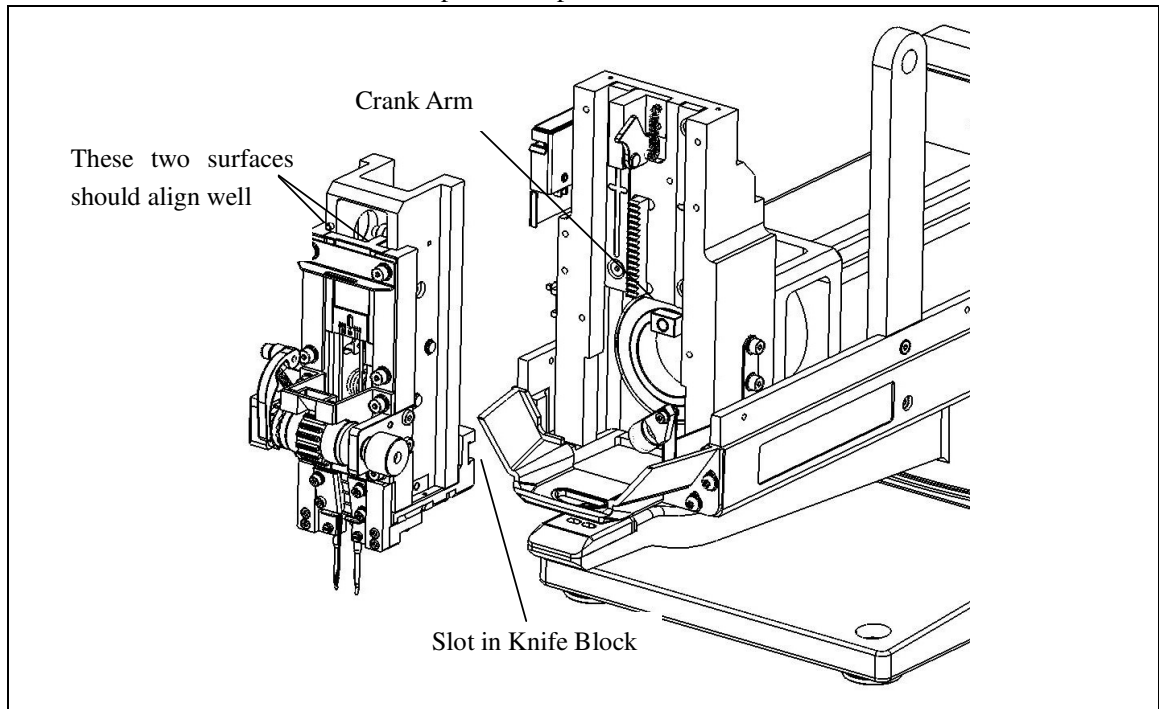

3. Orient the ejector slide to make the top of the slide flush with the top of the slide's guide track.
4. Replace the head while making sure the crank arm drive pin is in the hole of the crank bushing.
5. Replace the two slide plates.
6. Replace and adjust the sensor assembly.
 - 1) Loosen 2 screws holding sensor.
 - 2) Raise sensor to top most position.
 - 3) Turn machine to "CONTINUOUS" mode and 0.2s speed.
 - 4) Operate machine so cycles.
 - * If cycling is smooth, tighten screws.
 - * If cycle is fast, then slow loosen screws, move sensor down 0.5 mm, and retighten screws.
 - * Continue moving sensor down until cycle is smooth.
7. Replace the Feed Stop and tighten the screws.

Removing the Ejector Slide

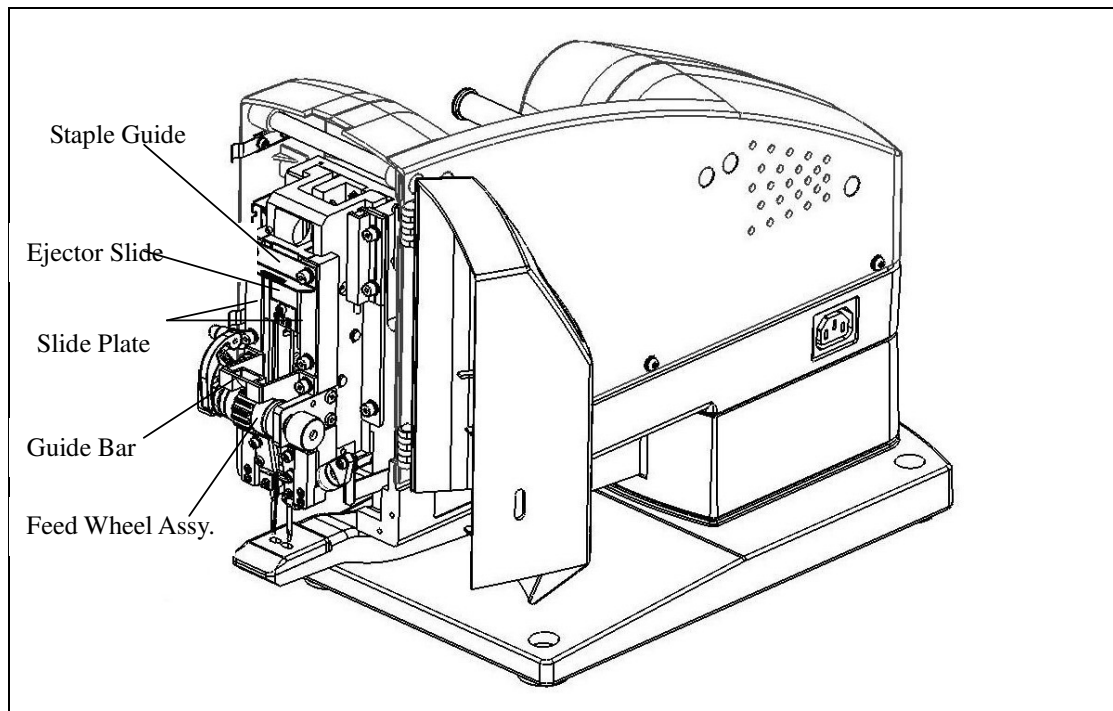

1. Unplug the unit.
2. With head and EJ slide in top position.
3. Remove the feed wheel assembly (see page 33).
4. Remove the four screws holding the feed guide and then remove the feed guide.

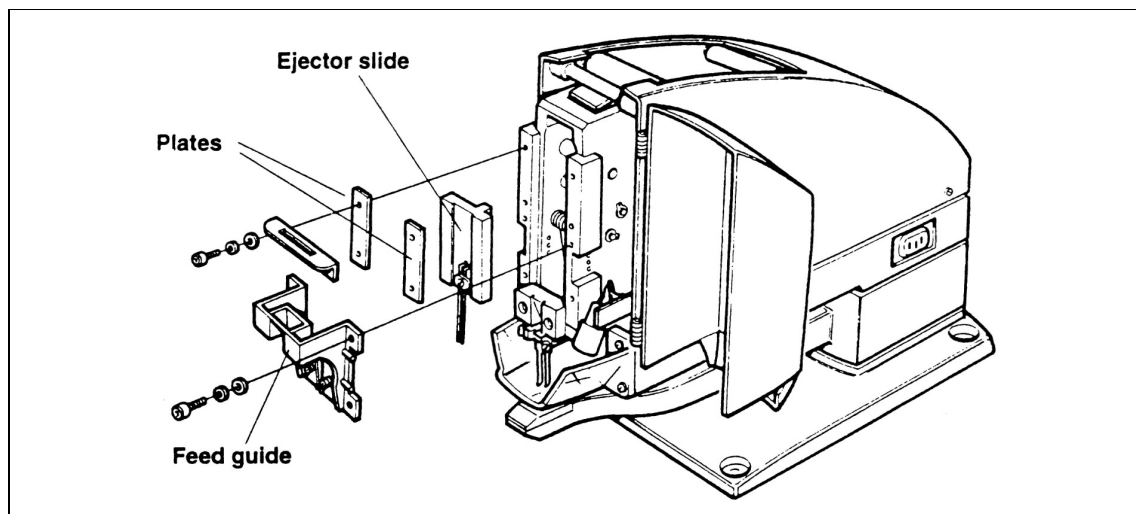

5. Remove the four screws from the two screw plates while holding the ejector slide. Remove the plates and the ejector slide.

Replacing the Knife Lever

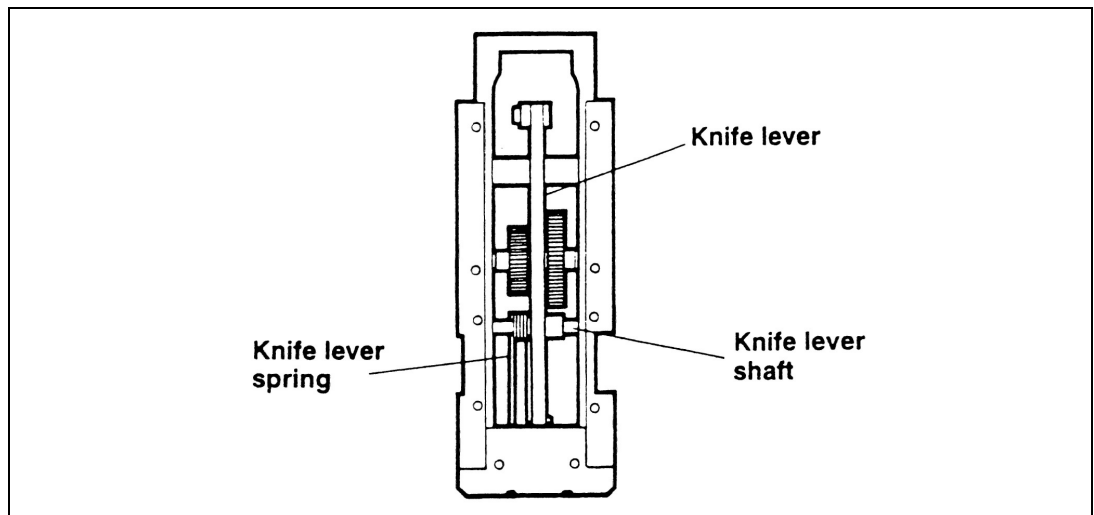

Disassembly

1. Unplug the unit.
2. Remove the feed wheel assembly (see page 33).
3. Remove the feed guide and the ejector slide (see page 37).
4. Disengage the spring from the bottom of the knife lever.
5. Remove the snap ring from the left side of the knife lever shaft.
6. Slide the shaft out and remove the lever and spring.

Assembly

1. Insert the knife lever shaft through the right side of the head, the knife lever, and spring.
2. Hook the spring to the bottom of the knife lever.
3. With the crank arm at top dead center, replace the ejector slide, positioning the top of the ejector slide flush with the top of the slide's guide track.
4. Holding the ejector slide in place, replace the ejector slide side plates.
5. Replace the feed guide.
6. Replace the feed wheel assembly.

Replacing and Aligning the Gears

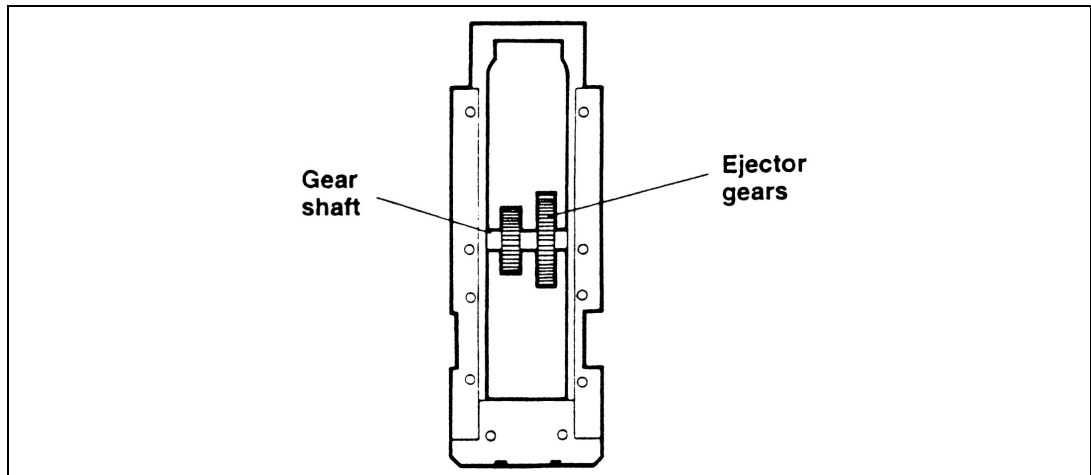

NOTE

The gears only need to be aligned if you replace them or if you removed the head when the ejector slide was removed and you didn't keep the gears aligned by inserting a tool into the alignment hole in the left side of the head (see page 37).

Disassembly

1. Unplug the unit.
2. Remove the feed wheel assembly (see page 31).
3. Remove the feed guide and the ejector slide (see page 36).
4. Remove the knife lever (see page 37).
5. Remove the retaining ring from the left side of the gear shaft.

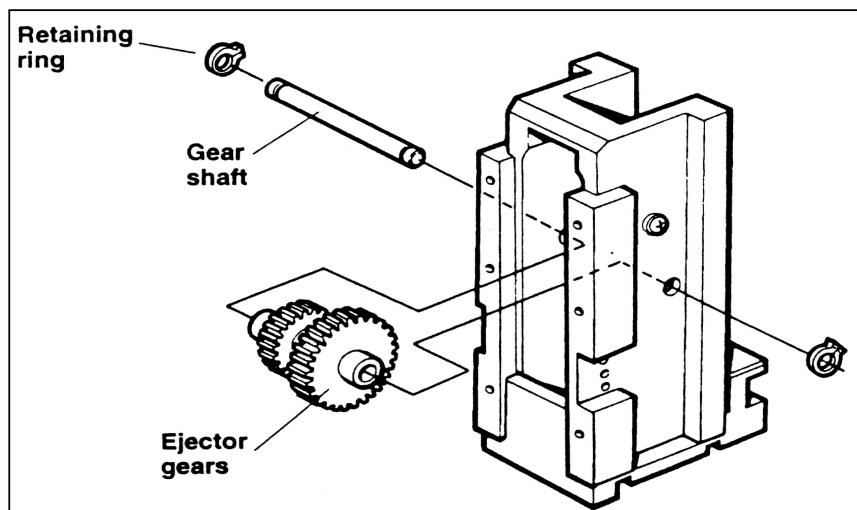

6. Remove the gear shaft from the head, removing the gears.

Assembly

1. Hold the gears in the gear slots cut in the head, with the large gear on the right.
2. Insert the gear shaft through the right side of the head and the gears.
3. Replace the snap ring on the left side of the gear shaft.
4. Rotate the gears so that the white timing mark on the large gear is in the front.
5. Align the white timing mark with the bottom tooth of the ejector slide when the head is off the machine.

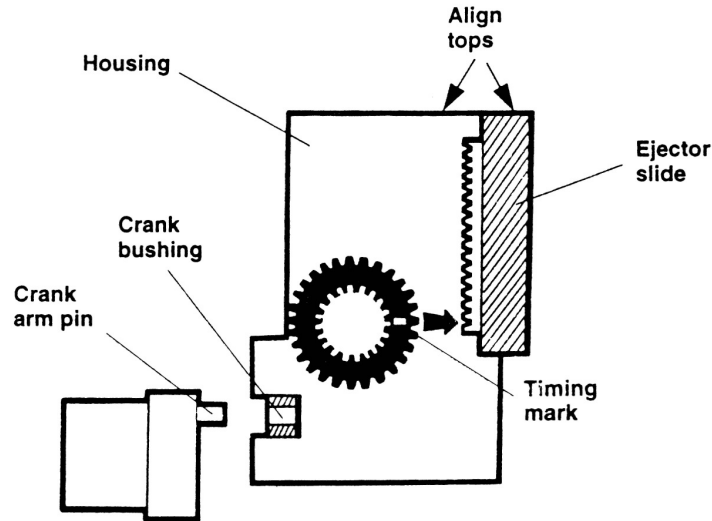

6. Replace the head by aligning the top of the ejector slide with the top of the slide's guide track.
7. Make sure the crank arm pin is at top dead center, then insert the crank arm pin into the crank bushing.
8. Replace the head side plates and screws.
9. Remove the ejector slide.
10. Replace the knife lever and spring.
11. Lubricate the gears with grease (see Lubrication on page 54).
12. Replace the ejector slide, positioning the top of the ejector slide flush with the top of the slide's guide track.
13. Replace the feed guide.
14. Replace the feed wheel assembly.

Replacing the Circuit Board

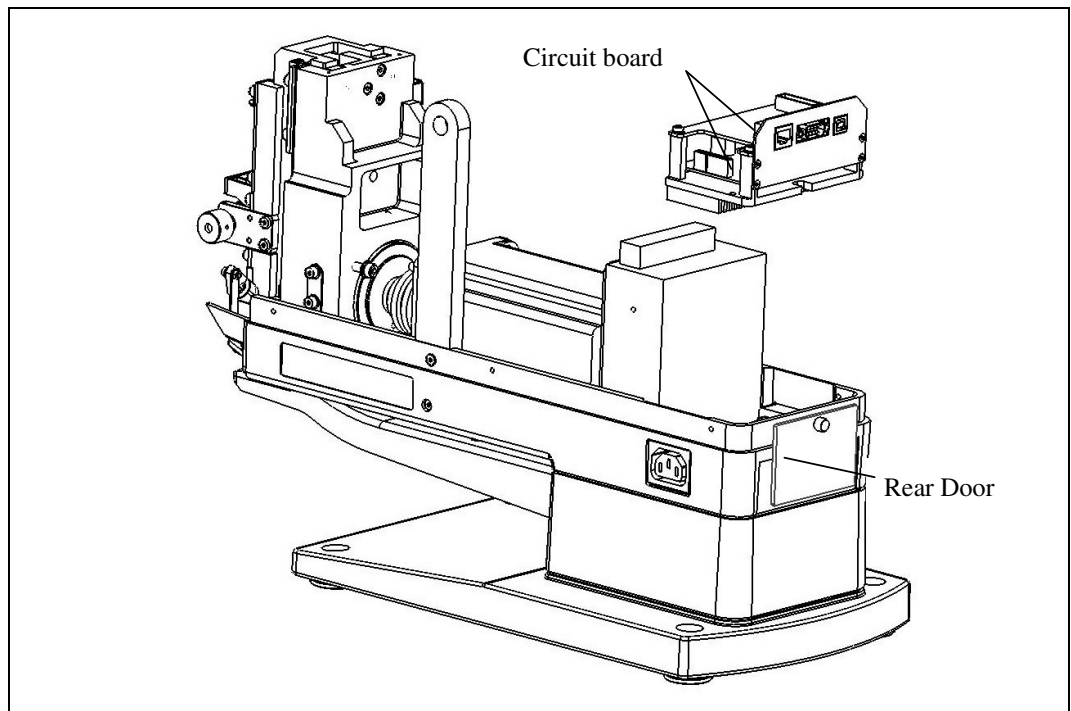

Disassembly

1. Unplug the unit.
2. Remove the reel support and the enclosure.
3. Loosen but don't remove the thumb screw on the Rear Door, rotate the Rear Door by 180 degrees and hang it on the thumb screw.
4. Disconnect the connectors.
5. Remove the three screws holding the circuit board.
6. Remove the circuit board assembly (the upper layer is MCU controller while the lower layer is Motor Driver).

Assembly

1. Position the circuit board so the four holes in the board align with the screw holes in the frame.
2. Insert and tighten the screws.
3. Connect the connectors.
4. Replace the Rear Door, Enclosure and Reel Support.

Replacing the Capacitor

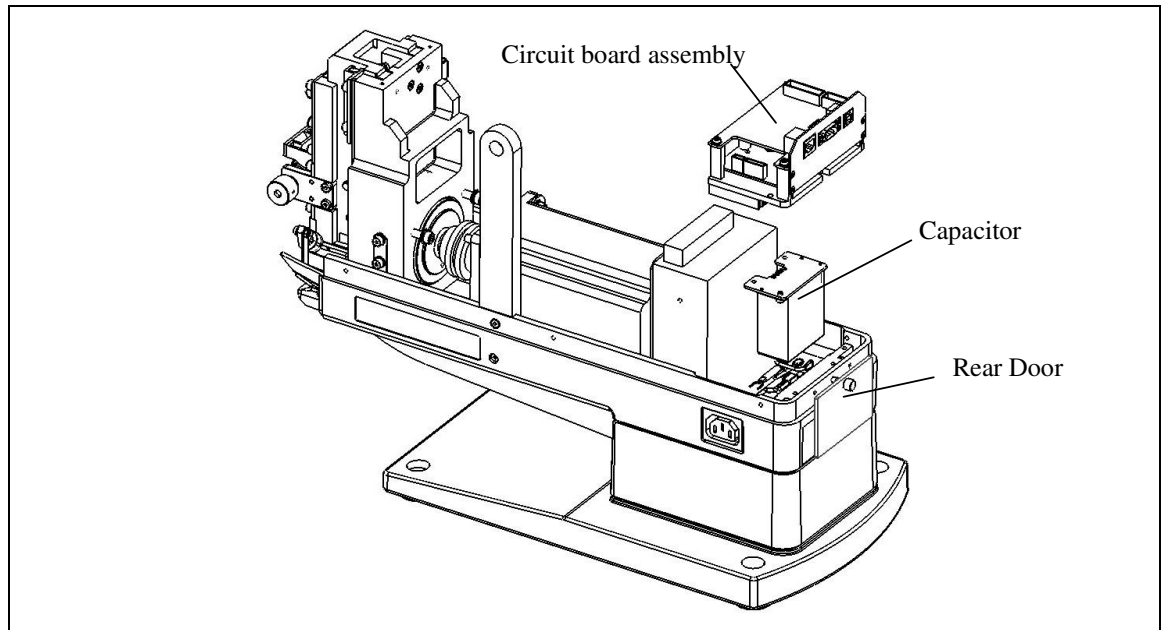

Disassembly

1. Unplug the unit.
2. Remove the reel support and the enclosure.
3. Loosen but don't remove the thumbscrew on the Rear Door, rotate the Rear Door by 180 degrees and hang it on the thumbscrew.
4. Remove the circuit board (see page 46).
5. Remove the two ground screws and take out the Capacitor.

Assembly

1. Position the Capacitor and tighten the screws.
2. Position the Circuit Board Assembly and tighten the screws.
3. Connect the connectors.
4. Replace the enclosure and the reel support, and Rear Door.

Replacing the Motor, Coupling, and Crank Arm Assembly

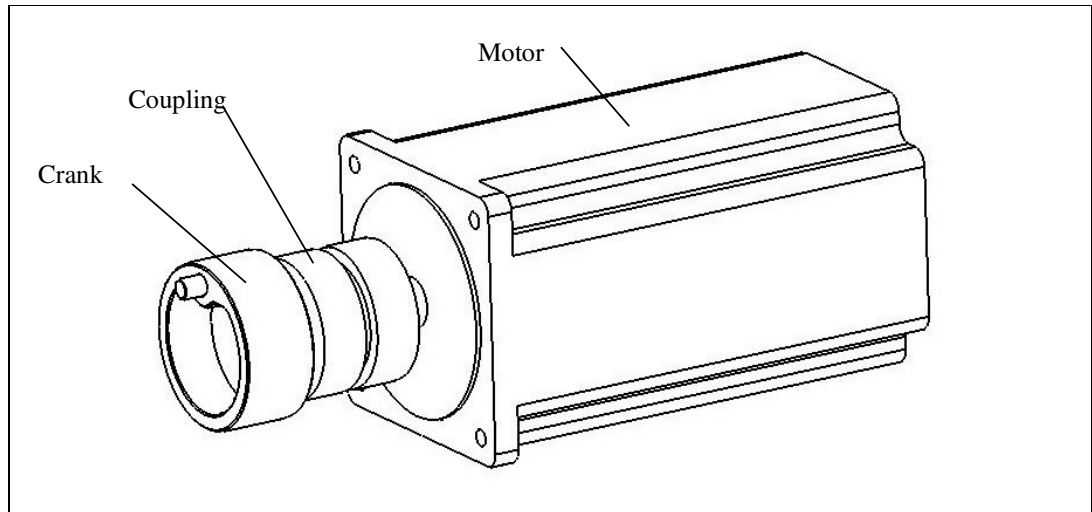

Disassembly

1. Unplug the unit.
2. Remove the reel support and the enclosure.
3. Unplug the motor, interlock switch, solenoid, and light connectors from the circuit board.

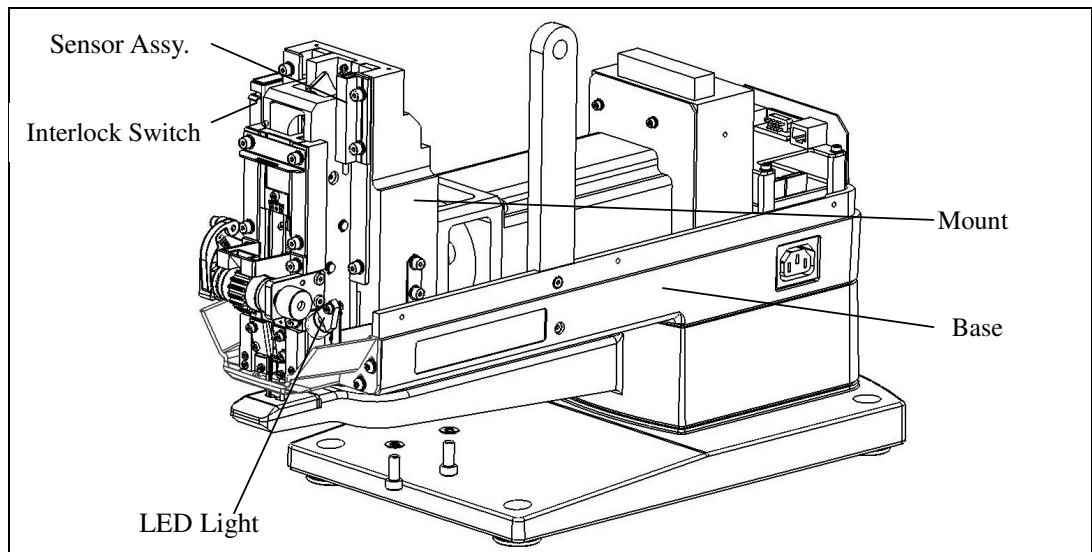

4. Remove the ground wire from the motor housing
5. Remove the four bolts from the bottom of the frame that secure the mount.
6. Remove the Motor, Coupling and Crank as one assembly.
7. Remove the four bolts holding the motor to mount.
8. Remove the motor, clutch, and crank arm from the mount. (If necessary, gently tap the collar from inside the mount to release it.)

Assembly

1. Make sure the head is in the top position.
2. Make sure the crank bushing is in the center of the horizontal track on the back of the head.
3. Make sure the crank arm pin is at top dead center.

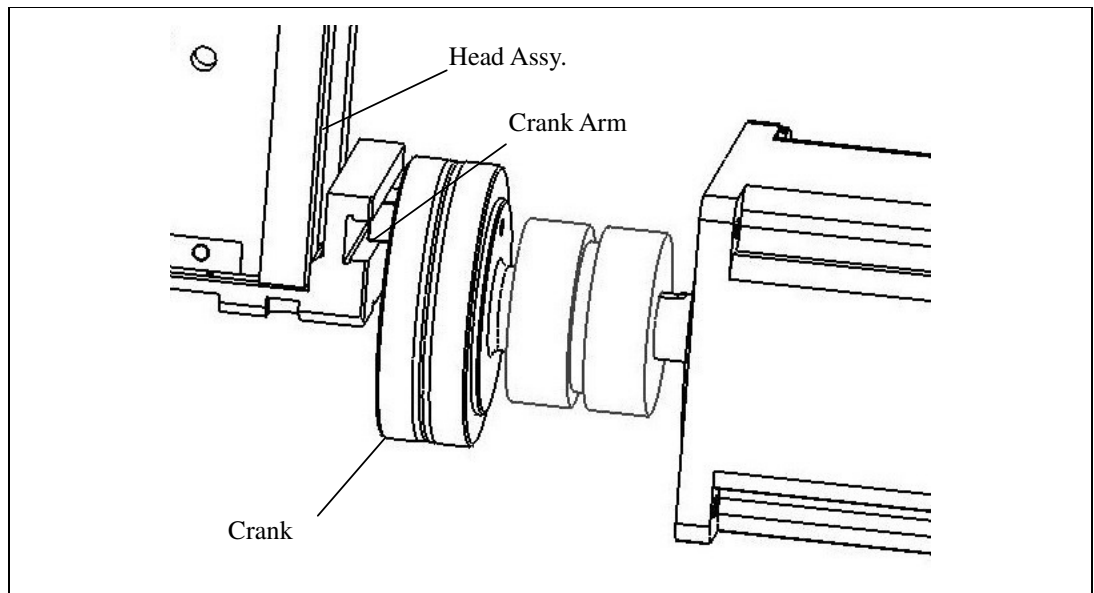

4. Insert the motor, clutch, and crank assembly into the mount.
5. Slowly insert the assembly into the frame. You must insert the pin extending from the crank arm into the bushing on the back of the head.
6. Press the collar into the hole in the frame.
7. Replace and tighten the four screws that hold the motor, coupling, and crank arm assembly to the mount.
8. Connect the two wires to the power switch.
9. Replace the motor, and head assembly in the frame, then insert and tighten the four screws that secure the mount.
10. Replace the ground wire on the motor housing.
11. Connect the motor, interlock switch, and light connectors from the circuit board.
12. Replace the enclosure and the reel support.

Replacing the Crank Arm

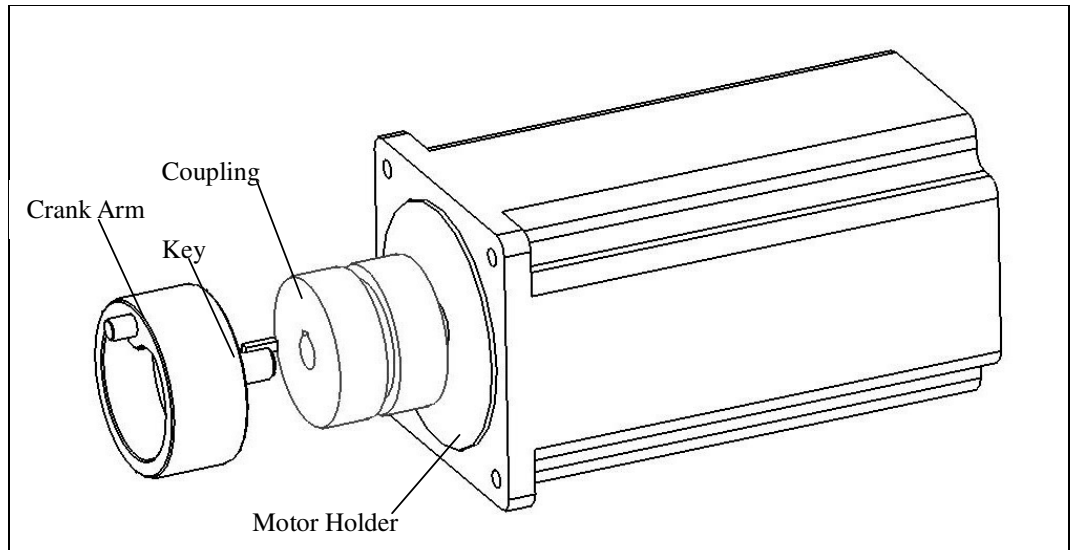

Disassembly

1. Unplug the unit.
2. Remove the motor, clutch, and crank arm assembly (see page 45).
3. Remove the screws holding the crank arm.
4. Remove the crank arm.

Assembly

1. Place the Key in the slot of crank arm.
2. Place the crank arm on the face of the coupling, aligning the pin on the crank arm with the cog on the coupling.
3. Insert and tighten the screws.

Removing the Coupling

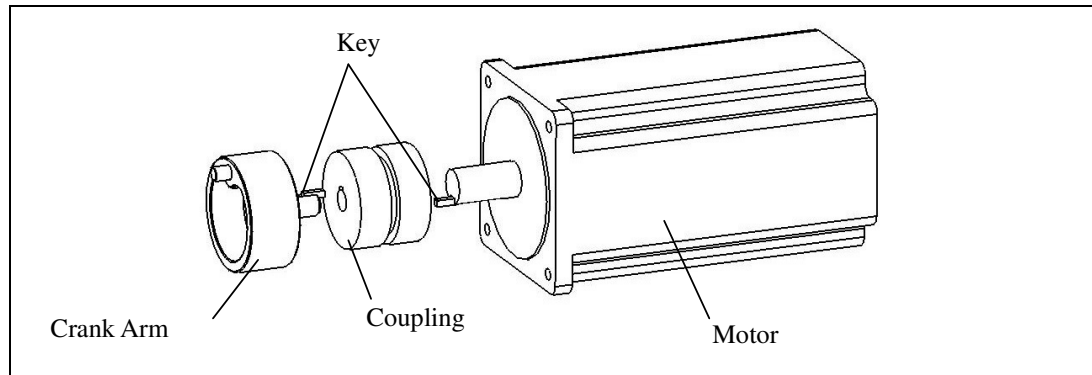

Disassembly

1. Unplug the unit.
2. Remove the motor, coupling, and crank arm assembly (see page 48).
3. Remove the crank arm (see page 50).
4. Remove the screw in the coupling holding the motor shaft.
5. Remove the coupling.

Assembly

1. Place the key of the coupling in the slot of the motor shaft.
2. Mount the coupling and tighten the screw holding the motor shaft.
3. Place the key of the crank arm in the slot of coupling
4. Mount the crank arm and tighten the screw.
5. Reassemble the motor, clutch, and crank arm assembly.

Troubleshooting

This chapter describes symptoms, possible causes, and solutions for problems you may encounter when operating the ST9500.

The symptoms are divided into five categories:

- ST9500 doesn't actuate or actuates abnormally
- Panel doesn't display or works abnormally
- Host software program doesn't function properly
- Fastener problems
- Ejection problems

Operational Check

NOTE | After repair or reassembly, always perform the following operational check.

1. Replace the ST9500 enclosure and needle guard.

! WARNING	Do not operate the machine with the enclosure and needle guards removed. Needles and moving parts may cause serious personal injury.
------------------	---

2. Make sure the Power Switch is OFF (0) and plug in the power cord. The ST9500 should not cycle.
3. Turn the Power Switch ON (1). Check that motor is not running, the panel LCD displays well, and the LED light is on.
4. Press the foot switch. The ST9500 should cycle at the set parameters and then stop.
5. Load fasteners and test for correct fastener cut and insertion.

ST9500 Doesn't Actuate or Actuates Abnormally

Symptom	Probable Cause	Action
Machine does not actuate	No power supply	Check that the power cord is properly connected and the switch is powered on
	The front door is not closed properly	Close the front door properly so that the interlock switch is on
	The connection of wires, cables or connectors are loosen	Check the connection of wires, cables and connectors related to power, motor, switch etc.
Machine actuates abnormally	Sensor doesn't give out correct trigger signal	Check the connection of sensor
	Position of sensor is not proper	Check the sensor and make sure the screws do not loose and the position of sensor bracket is correct so that the Head always stops at the top
	Fabric are too thick for the motor to provide enough torque for the needle to penetrate	Reduce the layers of fabric
	Stepping motor loses its step	Check the coupling and make sure it is not loose

Panel doesn't Display or Works Abnormally

Symptom	Probable Cause	Action
LCD displays unstably	The 20Pconnector is loose	Check the 20P connection
No back light on LCD display	The LED lighting for LCD display is damaged	Replace LCD display module
Panel buttons do not operate	Firmware issue	Re-start the machine

Host Software Application Doesn't Function Properly

Symptom	Probable Cause	Action
Serial Port (RS232) cannot get connected	RS232 connector loose	Check the connection
	Wrong COM port selected	Select a correct COM port
Network cannot get connected	Network connector loose	Check the connection
	IP address not setup or wrongly setup	Check and make sure the IP address is properly setup
Host software	RS232 or network connection loose	Check the connection
	Firmware issue	Re-start the machine

Fastener Problems

Symptom	Probable cause	Action
Feed jam of fasteners	Bad fastener cut	Back out and re-cut fastener end. Then re-feed fasteners.
	Not feeding one fastener pitch	Adjust feed screw.
	Contamination of the feed guide, needles, or needle holder	Clean the fastener path with compressed air. (See Warning below.)
Fastener not being cut	Knife incorrectly installed or dull	Make sure the flat edge of the knife is facing up. Replace knife.
	Broken knife cam spring	Replace spring.
More or less than one fastener feeding each cycle	Feed screw out of adjustment	Adjust screw.
Fastener not being cut in center	Feed knob out of adjustment	Adjust by pushing in feed knob.

! WARNING

Always wear eye protection when using compressed air.

Ejection Problems

Symptom	Probable cause	Action
Fastener not ejecting	Bent ejector rods	Replace rods.
Ejector rods bending	Ejector slide not installed correctly	Readjust slide.
	Knife too tight	Check that knife can move freely.
	Broken knife lever spring	Replace spring.

Routine Maintenance and Lubrication

This chapter describes the routine maintenance and lubrication that the ST9500 requires.

Daily Maintenance

You should blow out the Plastic Staple path daily with compressed air to remove dust and any contaminants.

This is the only daily maintenance required.

CAUTION	Do not use any type of lubricant on the fastener path. Use only compressed air to clean it. Do not use any solvents on the ST9500.
----------------	---

! WARNING	Always wear eye protection when using compressed air.
------------------	--

Lubrication

You should lubricate the ST9500 approximately every six months or one million cycles.

The following areas should be lubricated with light grease:

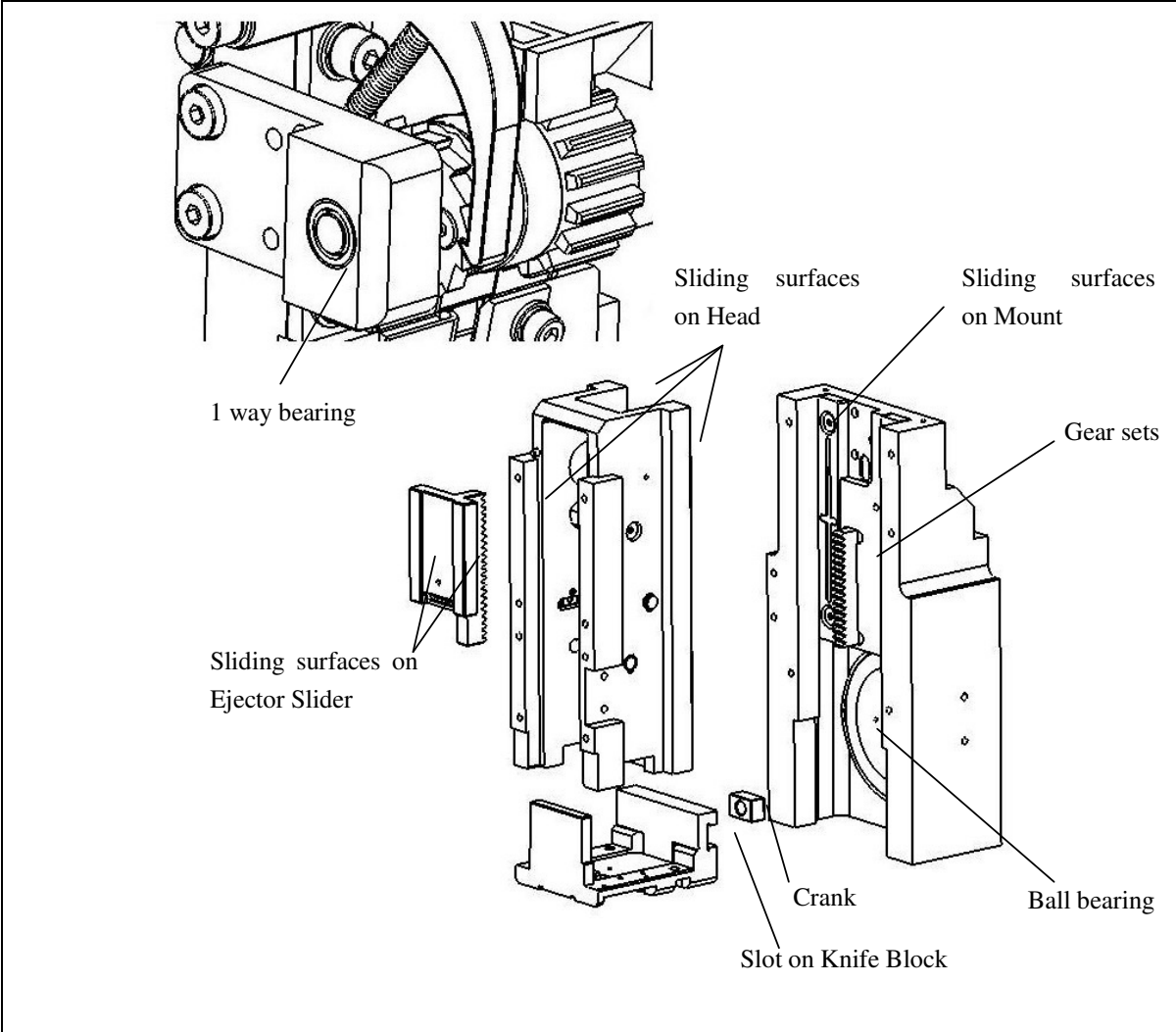

Routine Maintenance and Lubrication

The following areas should be lubricated with light sewing machine oil:

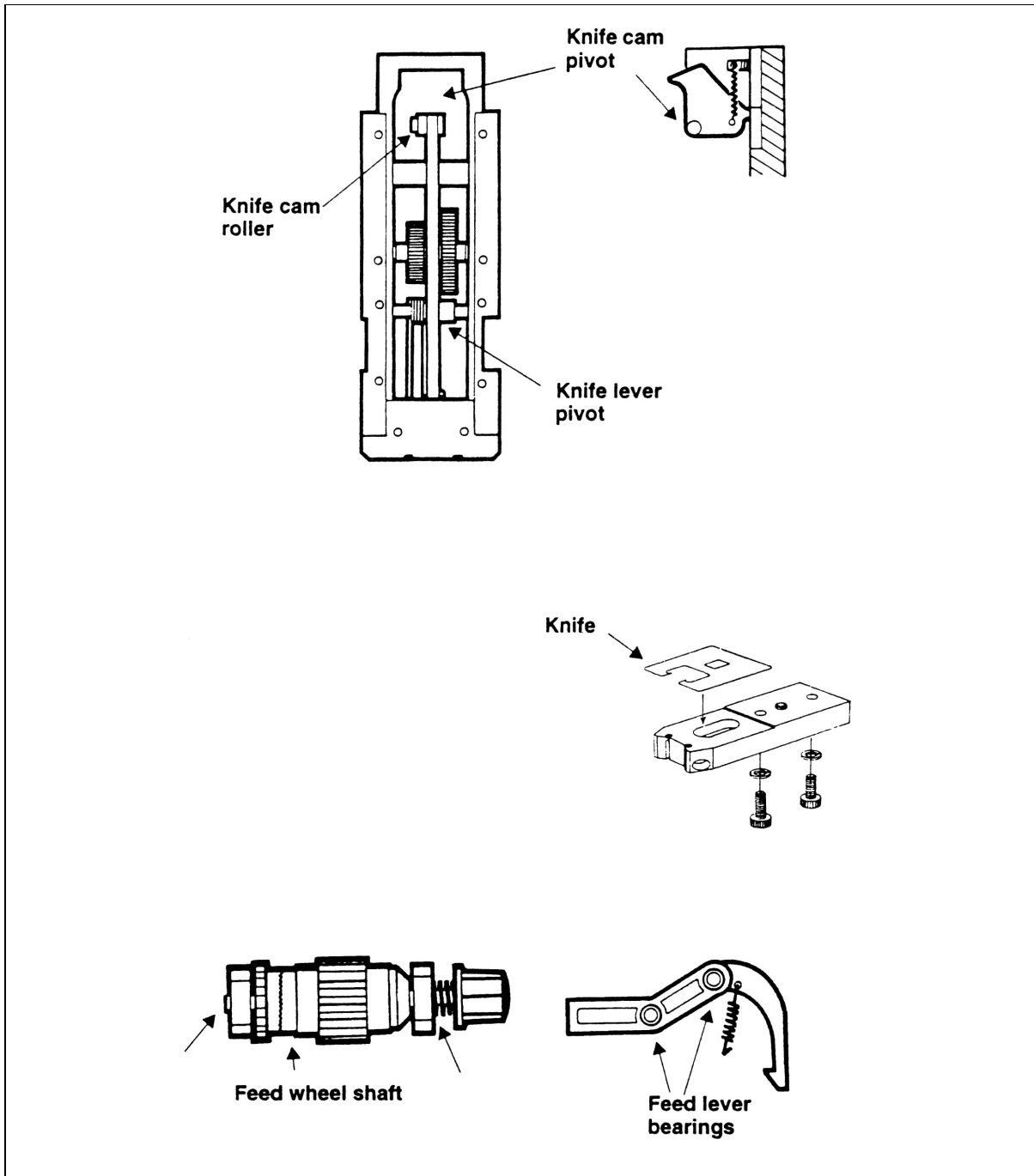

This chapter contains an illustrated list of parts in the ST9500™ machine.

To locate the part numbers and descriptions, match the key numbers in the illustrations with the key number column in the parts list.

Ordering Parts

To order replacement parts, contact your local Fastener Division sales office. A full list of worldwide contacts is included in the next chapter.

You will need the following information:

- ❑ The Avery Dennison part number and description from the list in this chapter
- ❑ The model number and serial number located on the back of the ST9500™ machine.

Factory Service

Depot factory service may be available. Contact your local Fastener Division sales office.

Whole Machine Exploded Illustration

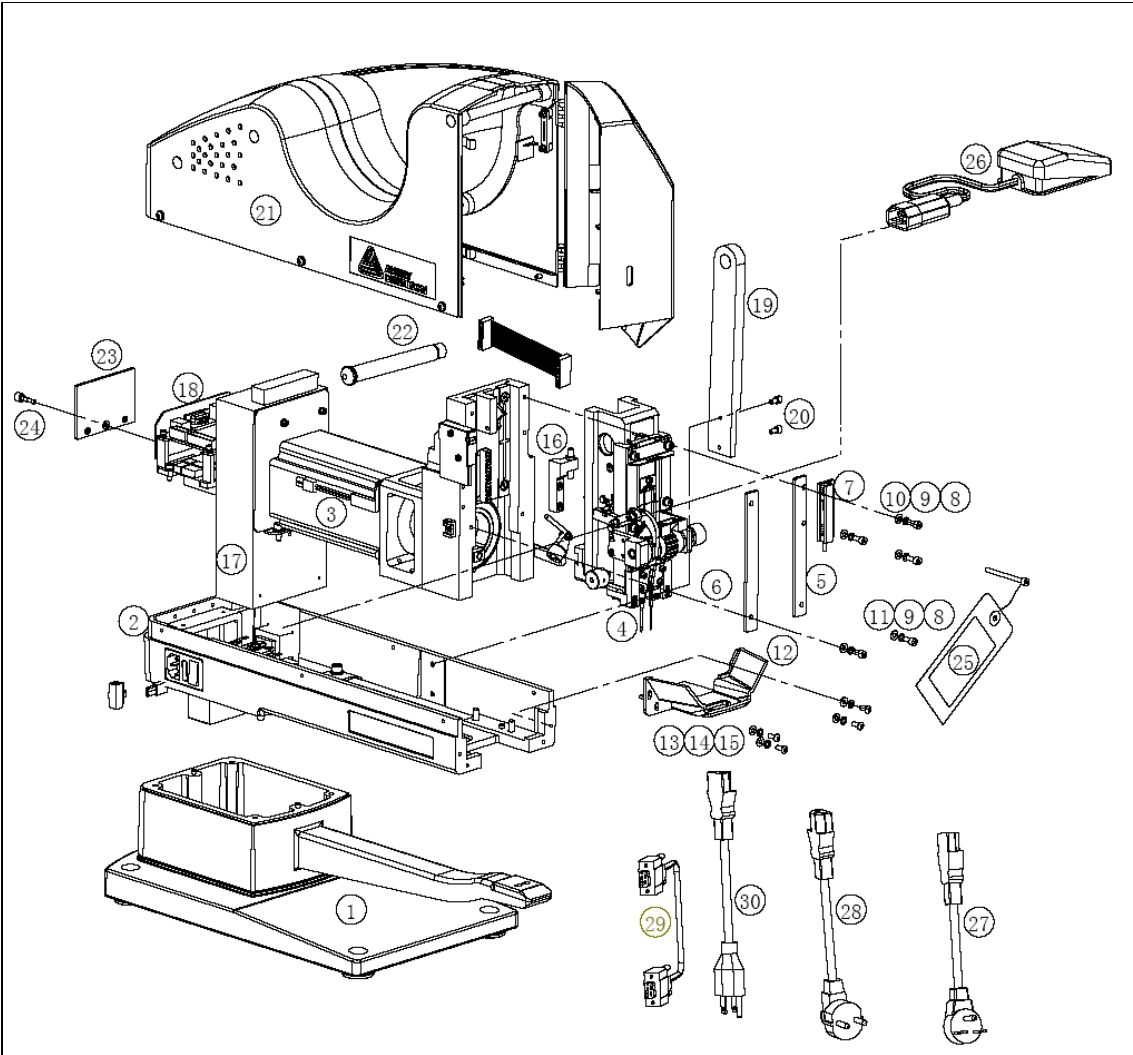

Whole Machine Spare Parts List

Item	P/N	Description	Qty.
1	3-06-0002-01	Assy, Base	1
2	3-06-0003-01	Assy, Body	1
3	3-06-0006-01	Assy, Motor	1
4	3-06-0013-01	Assy, Head	1
5	3-05-0048-01	Clamp, Mount Right	1
6	3-05-0049-01	Clamp, Mount, Left	1
7	3-06-0022-01	Assy, Hall sensor	1
8	140012012101	Washer, Black D4	5
9	140012008001	Lock Washer, Black D4	5
10	140001057401	Screw, Hexagon Socket Cup Head, Black 4X12	2
11	140001001201	Screw, Hexagon Socket Cup Head, Black 4X10	3
12	3-05-0050-01	Guard, Needle	1
13	140002010501	Screw, Hexagon Socket Half-Round Head, Stainless Steel 4X10	4
14	140012012601	Lock Washer, D4	4
15	140012000302	Washer, D4	4
16	3-06-0023-01	Assy, Stop, Feed	1
17	3-06-0024-01	Assy, switch power supply	1
18	3-06-0025-01	Assy, Driver	1
19	3-05-0065-01	Rod, Support	1
20	140001057701	Screw, Hexagon Socket Cup Head, Black 4X8	2
21	3-06-0026-01	Assy, Cover	1
22	3-05-0064-01	Mandrel, Feed	1
23	3-05-0066-01	Rear Pad, Standard	1
24	3-05-0082-01	Screw, Handle	1
25	DT0507-001	Shipping Tag & Screw	1
26	ST0525-001	Assy, Foot Switch	1
27	3-06-0035-01	Assy, Power 220v USA	1
28	3-06-0036-01	Assy, Power 220v EUROPE/ASIA	1
29	3-06-0037-01	Assy, Wire, COM	1
30	3-06-0041-01	Assy, Power 110v USA/JAPAN	1

Base Assembly and Body Assembly Exploded Illustration

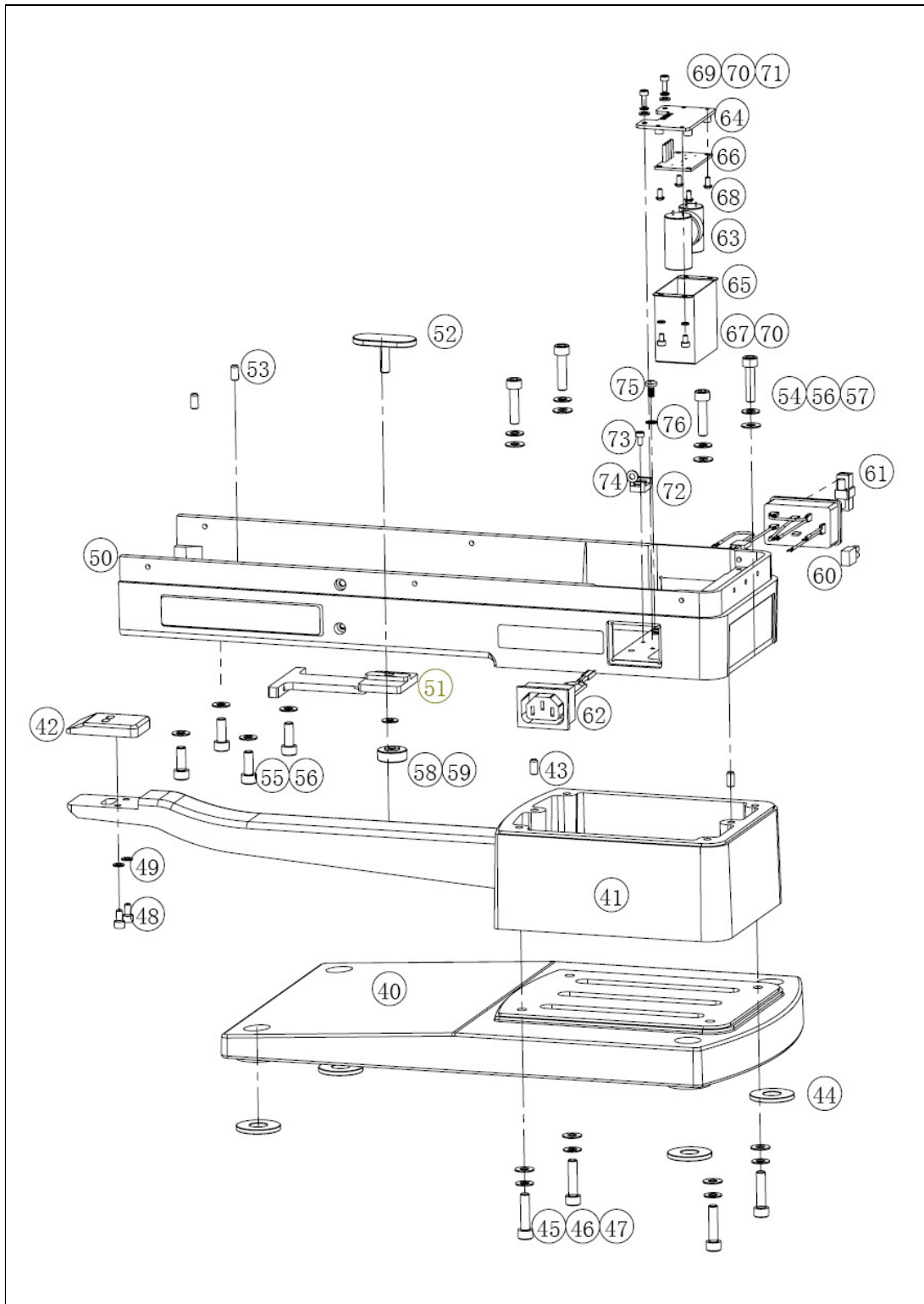

Base Assembly and Body Assembly Spare Parts List:

Item	P/N	Description	Qty.
40	3-05-0001-01	Base	1
41	3-05-0002-01	Arm, Reactor	1
42	3-05-0003-01	Plate, Reactor	1
43	DT0005-001	Pin 5, Locating	2
44	ST0605-001	Machine Buffer	4
45	140001022901	Screw, Hexagon Socket Cup Head, Black 6X25	4
46	140012008601	Washer, Black D6	4
47	140012008101	Lock Washer, Black D6	4
48	140001057701	Screw, Hexagon Socket Cup Head, Black 4X8	2
49	140012008001	Lock Washer, Black D4	2
50	3-05-0004-01	Body	1
51	3-05-0005-01	Stopper, Fabric	1
52	3-05-0006-01	Slider, Fabric Stopper	1
53	DT0005-001	Pin 5, Locating	2
54	140001022901	Screw, Hexagon Socket Cup Head, Black 6X25	4
55	140001003101	Screw, Hexagon Socket Cup Head, Black 6X16	4
56	140012008101	Lock Washer, Black D6	8
57	140012008601	Washer, Black D6	4
58	3-05-0094-01	Thumbscrew	1
59	140012015801	Washer, Black D5	1
60	3-06-0004-01	Assy, Receptacle, Power Cord	1
61	130028003201	Fuse	2
62	3-06-0005-01	Assy, Receptacle, Foot Switch	1
63	3-06-0039-01	Assy, Filter, Power supply	1
64	3-05-0086-01	Bracket, Capacitor	1
65	3-05-0087-01	Cover, Capacitor	1
66	3-06-0040-01	Sub Assy, Circuit, Filter	1
67	140001048702	Screw, Hexagon Socket Cup Head, Black 3X5	4
68	140002011001	Screw, Hexagon Socket Half-Round Head, Stainless Steel 3X6	4
69	140001001002	Screw, Hexagon Socket Cup Head, Black 3X8	2
70	140012007901	Lock Washer, Black D3	6
71	140012012201	Washer, Black D3	2
72	130903001401	Tie, Fixer	1
73	140001000802	Screw, Hexagon Socket Cup Head, Black 3X6	1
74	130901001401	Tie, Self-Clinching, Nylon	1
75	140002010801	Screw, Half-Round Crossed Head, Stainless Steel 4X8	1
76	140012012301	Washer, T-Lock, D4	1

Motor Assembly Exploded Illustration

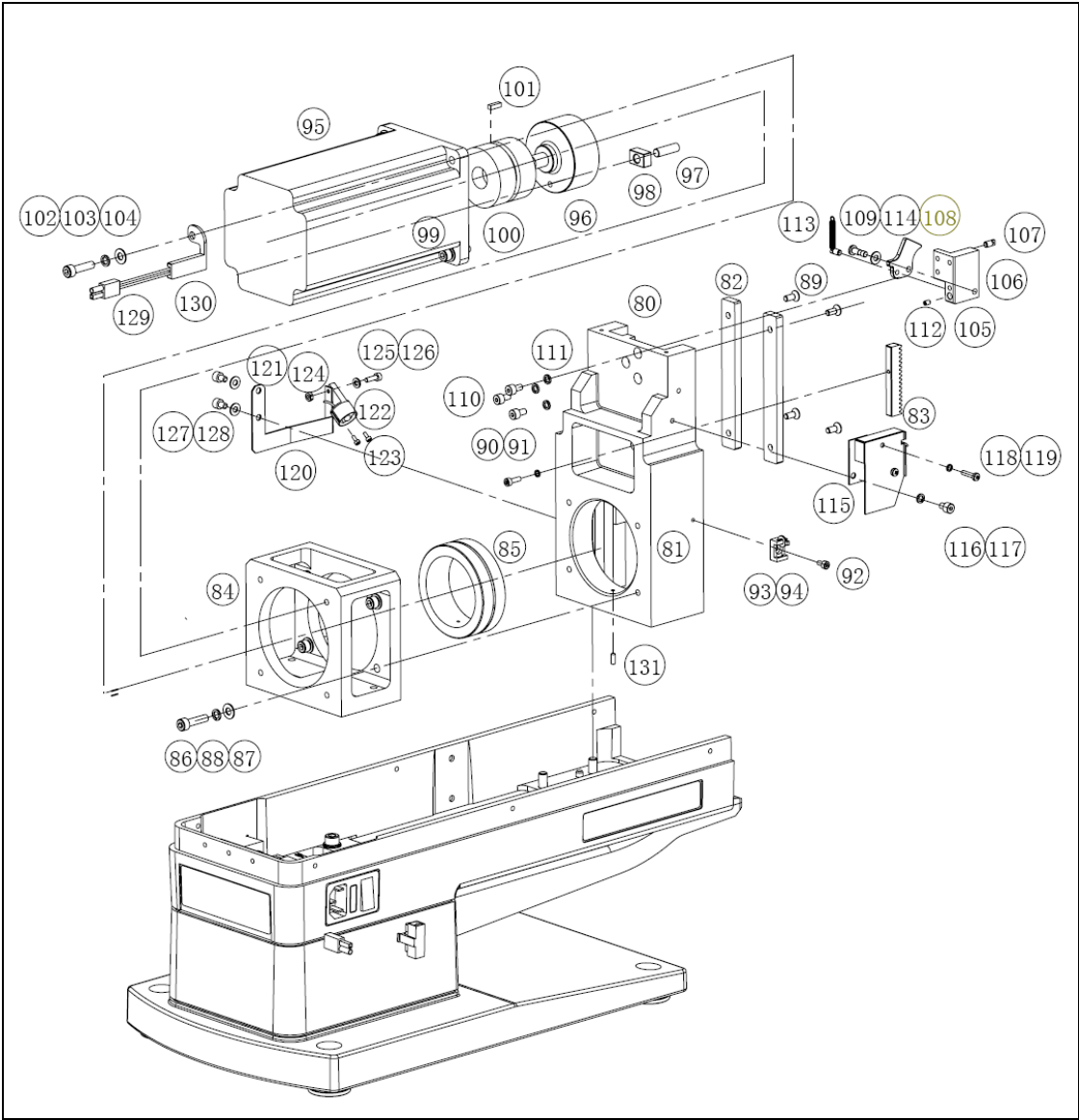

Motor Assy Spare Parts List:

Item	P/N	Description	Qty.
80	3-06-0007-01	Assy, Mount	1
81	3-05-0007-01	Mount	1
82	3-05-0008-01	Wear Strip	2
83	DT0210-001	Rack-6	1
84	3-05-0009-01	Holder, Motor	1
85	110013016301	Bearing, Needle Roller	1
86	140001002501	Screw, Hexagon Socket Cup Head, Black 5X20	4
87	140012015801	Washer, Black D5	4
88	140012010601	Lock Washer, Black D5	4
89	140003006201	Screw, Hexagon Socket Countersunk Head, Black 4X10	4
90	140001000302	Screw, Hexagon Socket Cup Head, Black 3X12	1
91	140012007901	Lock Washer, Black D3	1
92	140001000802	Screw, Hexagon Socket Cup Head, Black 3X6	1
93	130903001401	Tie, Fixer	1
94	130901001401	Tie, Self-Clinching, Nylon	1
95	3-06-0008-01	Assy, Motor	1
96	3-05-0010-01	Ring, Offset	1
97	DT0222-001	Pin 1, Offset Ring	1
98	DT0224-001	Bushing, Square	1
99	130305012301	Step Motor	1
100	110012006201	Coupling	1
101	110042000501	Key	1
102	140001002501	Screw, Hexagon Socket Cup Head, Black 5X20	4
103	140012015801	Washer, Black D5	4
104	140012010601	Lock Washer, Black D5	4
105	3-06-0009-01	Assy, Knife Cam	1
106	DT0206-001	Support, Knife Cam	1
107	DT0163-001	Post, Tension Spring	2
108	DT0207-001	Cam, Knife	1
109	DT0209-001	Pin, Cam, Knife	1
110	140001057701	Screw, Hexagon Socket Cup Head, Black 4X8	3
111	140012008001	Lock Washer, Black D4	3
112	140004000702	Trip Bolt, Hexagon Socket Head, Black 3X5	1
113	110016038101	Spring, Pawl	1
114	140012012101	Washer, Black D4	1
115	3-06-0010-01	Assy, Inter Lock Switch	1

116	140001057601	Screw, Hexagon Socket Cup Head, Black 4X6	2
117	140012008001	Lock Washer, Black D4	2
118	140002006502	Screw, Half-Round Crossed Head, Stainless Steel 3X14	2
119	140012007901	Lock Washer, Black D3	2
120	3-06-0011-01	Assy, Lamp	1
121	3-05-0011-01	Plate, Lamp	1
122	ST0324-001	Shade, Lamp	1
123	140001057101	Screw, Hexagon Socket Cup Head, Stainless Steel 2X5	2
124	140011003701	Nut, Hexagon M3	1
125	140001000302	Screw, Hexagon Socket Cup Head, Black 3X10	1
126	140012012201	Washer, Black D3	1
127	140001057601	Screw, Hexagon Socket Cup Head, Black 4X6	2
128	140012012101	Washer, Black D4	2
129	3-06-0012-01	Assy, Thermal Protector	1
130	3-05-0012-01	Holder, Thermal Protector	1
131	140004029201	Trip Bolt, Hexagon Socket Head, Black 3X8	1

Head Subassembly and Knife Lever Assembly Exploded Illustration

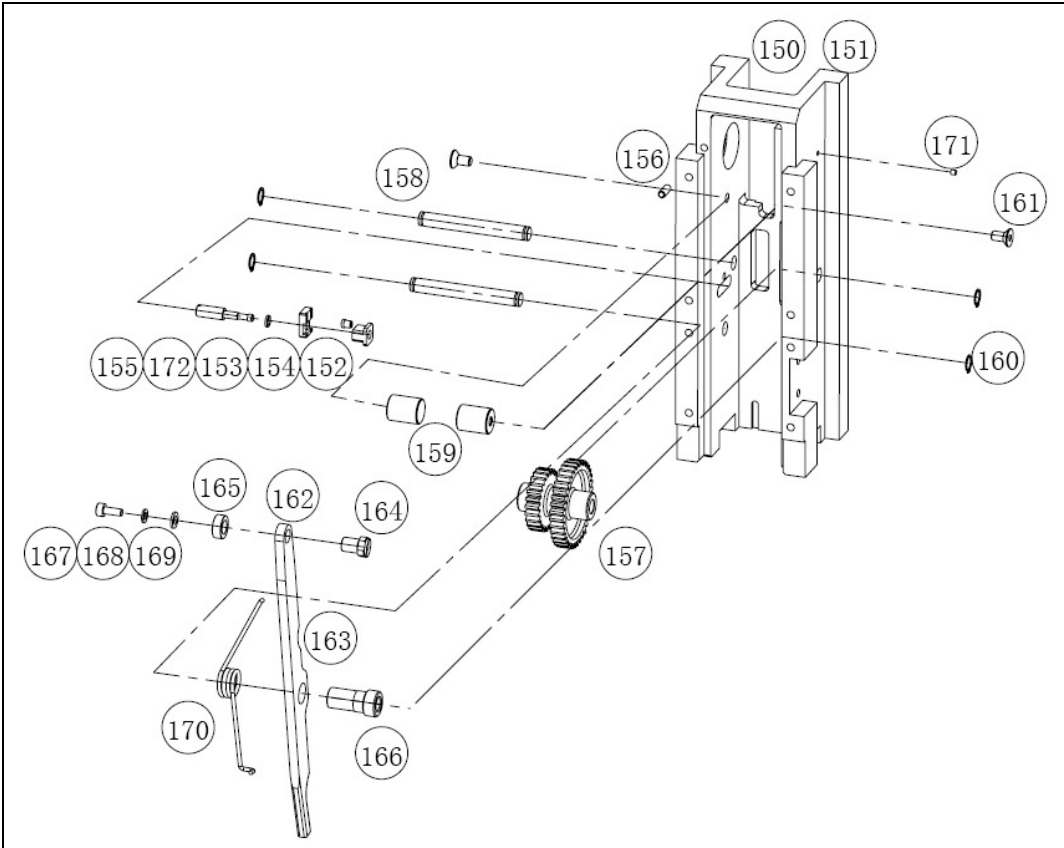

Head Subassembly and Knife Lever Assembly Spare Parts List:

Item	P/N	Description	Qty.
150	3-06-0014-01	Sub Assy, Head	1
151	3-05-0013-01	Housing	1
152	3-05-0014-01	Block, Slide, Rear, Shot Mode	1
153	3-05-0015-01	Block, Slide, Front, Shot Mode	1
154	110020003101	Ball detent	1
155	3-05-0016-01	Adjust Rod, Space, Shot Mode	1
156	110015022401	Pin, Spring	1
157	DT0108-001	Spur Gears	1
158	DT0116-001	Shaft, Knife Lever	2
159	DT0106-001	Guide, Knife Lever	2
160	110017000101	C Ring, Shaft	4
161	140003009001	Screw, Hexagon Socket Countersunk Head, Black 4X8	2
162	3-06-0015-01	Assy, Knife Lever	1
163	3-05-0017-01	Lever, Knife	1
164	DT0112-001	Shaft, Knife Roller	1
165	DT0113-001	Roller, Knife Lever	1
166	DT0114-001	Bearing, Knife Lever	1
167	140001001002	Screw, Hexagon Socket Cup Head, Black 3X8	1
168	140012007901	Lock Washer, Black D3	1
169	140012012201	Washer, Black D3	1
170	DT0115-001	Spring, Knife Lever	1
171	130907000902	Magnet	1
172	140012007901	Lock Washer, Black D3	1

Base, Knife Assembly Exploded Illustration

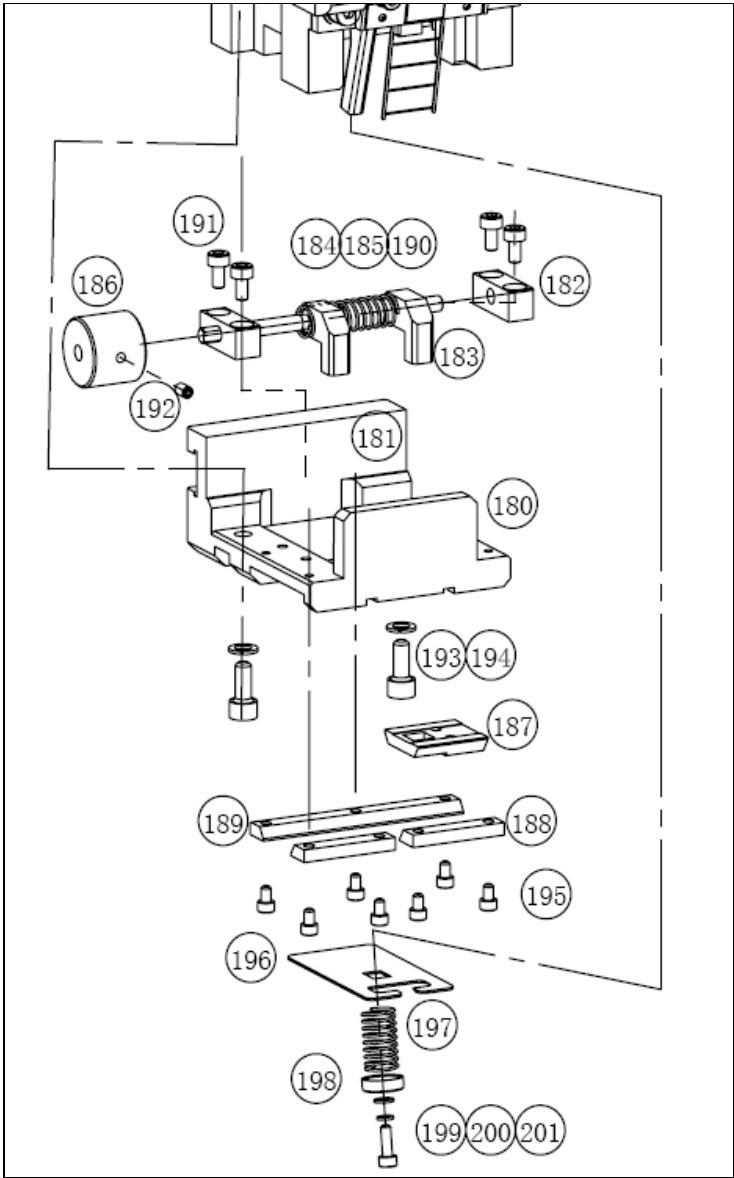

Base, Knife Assembly Spare Parts List:

Item	P/N	Description	Qty.
180	3-06-0016-01	Assy, Base, Knife	1
181	3-05-0018-01	Base, Knife	1
182	3-05-0019-01	Support, Shaft	2
183	3-05-0020-01	Nut, Right	1
184	3-05-0021-01	Bolt, Adjust	1
185	3-05-0022-01	Nut, Left	1
186	3-05-0023-01	Handle, Adjust	1
187	3-05-0024-01	Block, Guide, V Shape	2
188	3-05-0025-01	Block, Guide	2
189	3-05-0026-01	Block, Guide, Long	1
190	3-05-0068-01	Spring, adjust needle space	1
191	140001000802	Screw, Hexagon Socket Cup Head, Black 3X6	4
192	140004000702	Trip Bolt, Hexagon Socket Head, Black 3X5	1
193	140001001201	Screw, Hexagon Socket Cup Head, Black 4X10	2
194	140012008001	Lock Washer, Black D4	2
195	140001065401	Screw, Hexagon Socket Cup Head, Black 2.5X4	7
196	3-05-0027-01	Knife	1
197	3-05-0069-01	Spring, hold knife	1
198	3-05-0028-01	Cover, Spring	1
199	140001047002	Screw, Hexagon Socket Cup Head, Black 2.5X8	1
200	140012016201	Lock Washer, D2.5	1
201	140012016301	Washer, D2.5	1

Left and Right Needle Holder Assembly Exploded Illustration

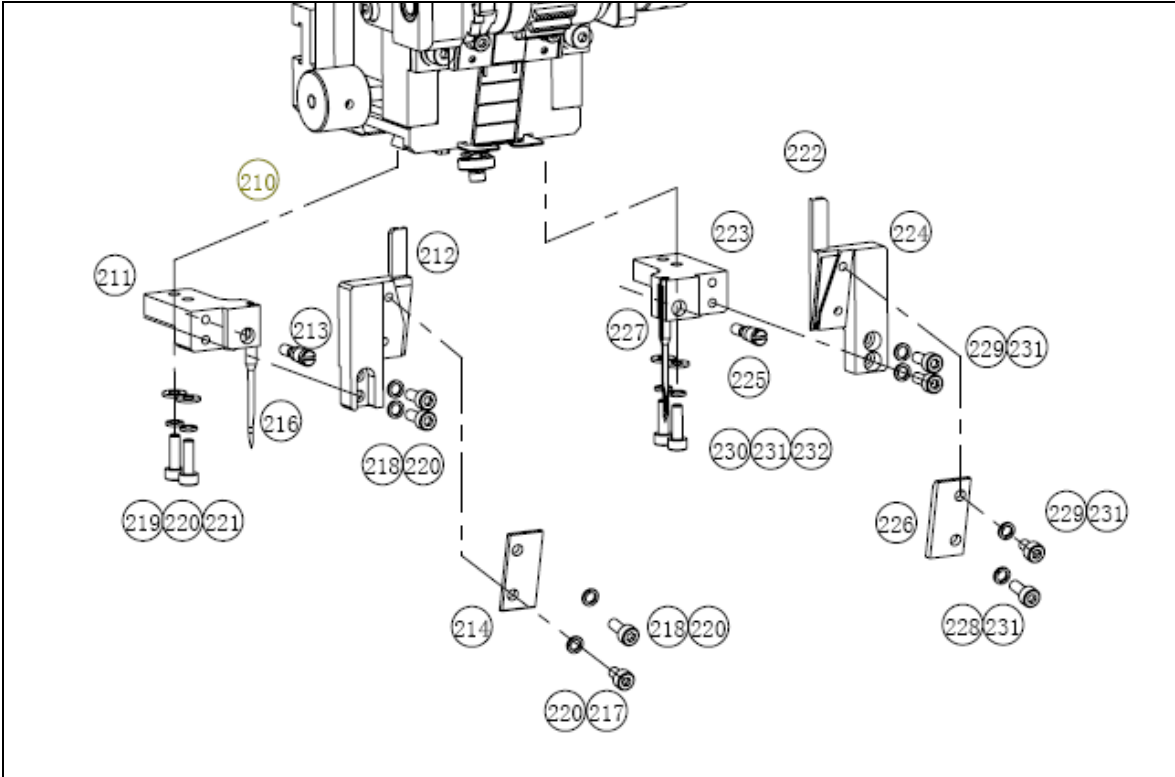

Left and Right Needle Holder Assembly Spare Part List:

Item	P/N	Description	Qty.
210	3-06-0017-01	Assy, Holder, Needle, Left	1
211	3-05-0029-01	Holder, Needle, Left	1
212	3-05-0030-01	Block, Guider, Left	1
213	3-05-0083-01	Screw, Needle Lock	1
214	3-05-0078-01	Plate, Rod Block, Left	1
216	15010-0 TM	Plastic Staple® Fine Fabric Needle	1
216	15011-0 TM	Plastic Staple® Ultra Fine Fabric Needle	1
217	140001048702	Screw, Hexagon Socket Cup Head, Black 3X5	1
218	140001001002	Screw, Hexagon Socket Cup Head, Black 3X8	3
219	140001000302	Screw, Hexagon Socket Cup Head, Black 3X10	2
220	140012007901	Lock Washer, Black D3	6
221	140012012201	Washer, Black D3	2
222	3-06-0018-01	Assy, Holder, Needle, Right	1
223	3-05-0031-01	Holder, Needle, Right	1
224	3-05-0032-01	Block, Guider, Right	1
225	3-05-0083-01	Screw, Needle Lock	1
226	3-05-0080-01	Plate, Rod Block, Right	1
227	15010-0 TM	Plastic Staple® Fine Fabric Needle	1
227	15011-0 TM	Plastic Staple® Ultra Fine Fabric Needle	1
228	140001048702	Screw, Hexagon Socket Cup Head, Black 3X5	1
229	140001001002	Screw, Hexagon Socket Cup Head, Black 3X8	3
230	140001000302	Screw, Hexagon Socket Cup Head, Black 3X10	2
231	140012007901	Lock Washer, Black D3	6
232	140012012201	Washer, Black D3	2

Guide Bar Assy., Feed Assy. and Feed Lever Assy. Exploded Illustration

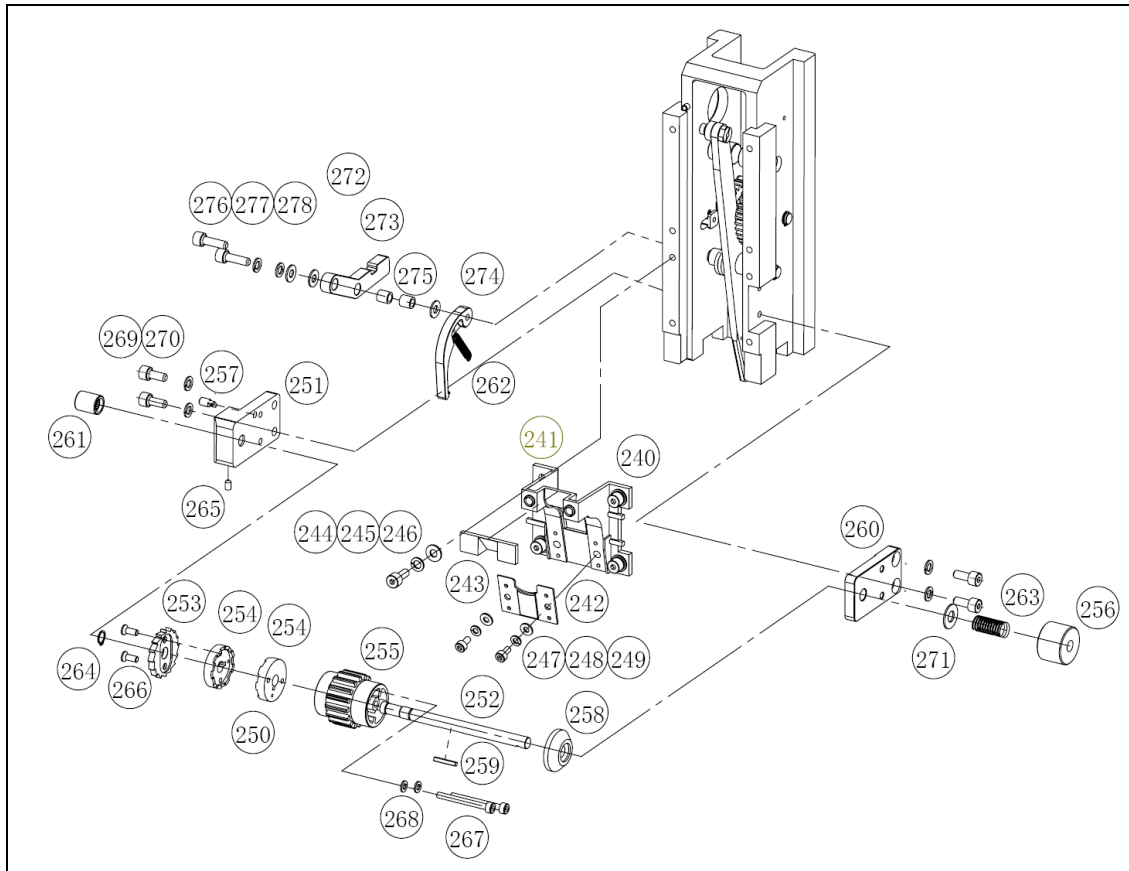

Guide Bar Assy., Feed Assy. and Feed Lever Assy. Spare Parts List:

Item	P/N	Description	Qty.
240	3-06-0019-01	Assy, Guide Bar	1
241	3-05-0035-01	Guide Bar, Staple	1
242	3-05-0036-01	Plate, Guide	1
243	DT0133-001	Guide, L-shaped Staple	1
244	140001001201	Screw, Hexagon Socket Cup Head, Black 4X10	4
245	140012008001	Lock Washer, Black D4	4
246	140012012101	Washer, Black D4	4
247	140001000802	Screw, Hexagon Socket Cup Head, Black 3X6	2
248	140012007901	Lock Washer, Black D3	2
249	140012012201	Washer, Black D3	2
250	3-06-0020-01	Assy, Feed	1
251	3-05-0037-01	Plate, Support, Left	1
252	3-05-0038-01	Shaft, Feed	1
253	3-05-0039-01	Ratchet, Feed	1
254	3-05-0040-01	Clutch, Feed	2
255	3-05-0041-01	Gear, Feed	1
256	3-05-0042-01	Handle, Feed	1
257	DT0163-001	Post, Tension Spring	1
258	DT0137-001	Collar, Feed	1
259	DT0140-001	Key	1
260	DT0145-001	Plate, Support, Right	1
261	110013021701	Roller bearing, one way	1
262	110016038101	Spring, Pawl	1
263	110016038201	Spring, Feed	1
264	110017000101	C Ring, Shaft	1
265	140004000702	Trip Bolt, Hexagon Socket Head, Black 3X5	2
266	140003005402	Screw, Hexagon Socket Countersunk Head, Black 3X8	2
267	140001000602	Screw, Hexagon Socket Cup Head, Black 3X30	2
268	140012007901	Lock Washer, Black D3	2
269	140001001201	Screw, Hexagon Socket Cup Head, Black 4X10	4
270	140012008001	Lock Washer, Black D4	4
271	140012008601	Washer, Black D6	1
272	3-06-0021-01	Assy, Lever Feed	1
273	3-05-0043-01	Lever, Feed	1
274	3-05-0044-01	Pawl, Feed	1
275	DT0156-001	Spacer 6	2
276	140001063901	Screw, Hexagon Socket Cup Head, Black 4X14	2
277	140012012101	Washer, Black D4	3
278	140012008001	Lock Washer, Black D4	2

Hall Sensor Assy., Feed Stop Assy. and other Parts Exploded Illustration

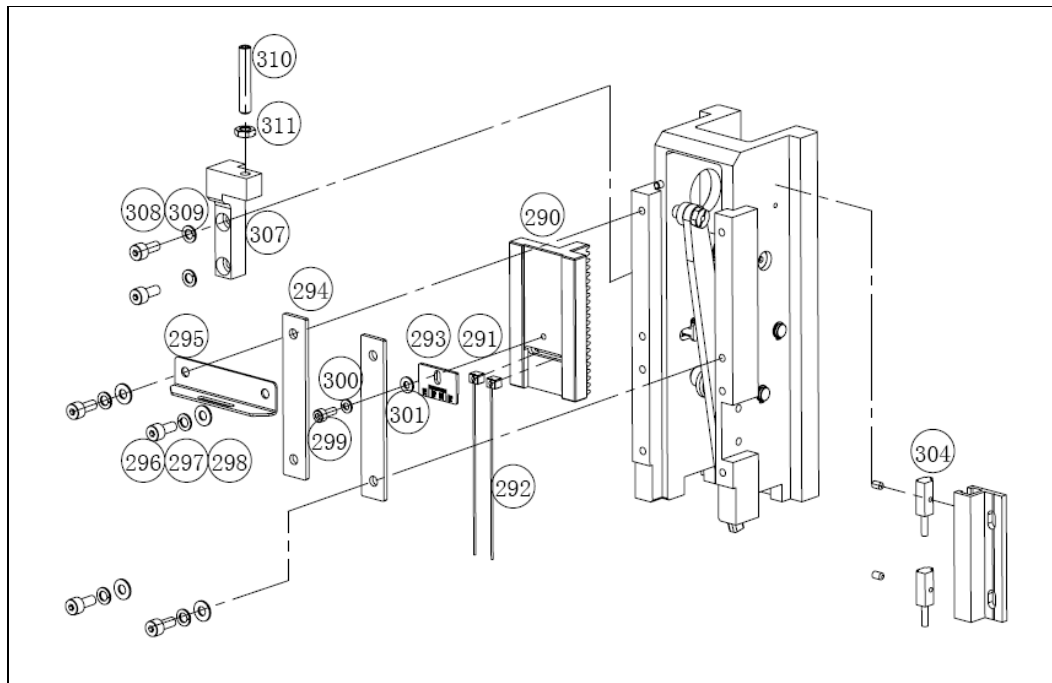

Hall Sensor Assy., Feed Stop Assy. and other Parts Spare Part List

Item	P/N	Description	Qty.
290	3-05-0033-01	Ejector Slide	1
291	3-05-0045-01	Slide, Ejector	2
292	7-60-2733-01	Rod, Ejector	2
293	3-05-0046-01	Plate, Scale	1
294	3-05-0081-01	Plate, Screw	2
295	3-05-0034-01	Entrance, Staple	1
296	140001001201	Screw, Hexagon Socket Cup Head, Black 4X10	4
297	140012012101	Washer, Black D4	4
298	140012008001	Lock Washer, Black D4	4
299	140001001002	Screw, Hexagon Socket Cup Head, Black 3X8	1
300	140012007901	Lock Washer, Black D3	1
301	140012012201	Washer, Black D3	1
304	630HAL0512	Hall sensor	2
307	3-05-0067-01	Stop, Feed	1
308	140001001201	Screw, Hexagon Socket Cup Head, Black 4X10	2
309	140012008001	Lock Washer, Black D4	2
310	140004028901	Trip Bolt, Hexagon Socket Cup Head, Black 5X30	1
311	140011005801	Nut, Hexagon, Black M5	1

Switch Power Supply Assy. and Driver Assy. Exploded Illustration

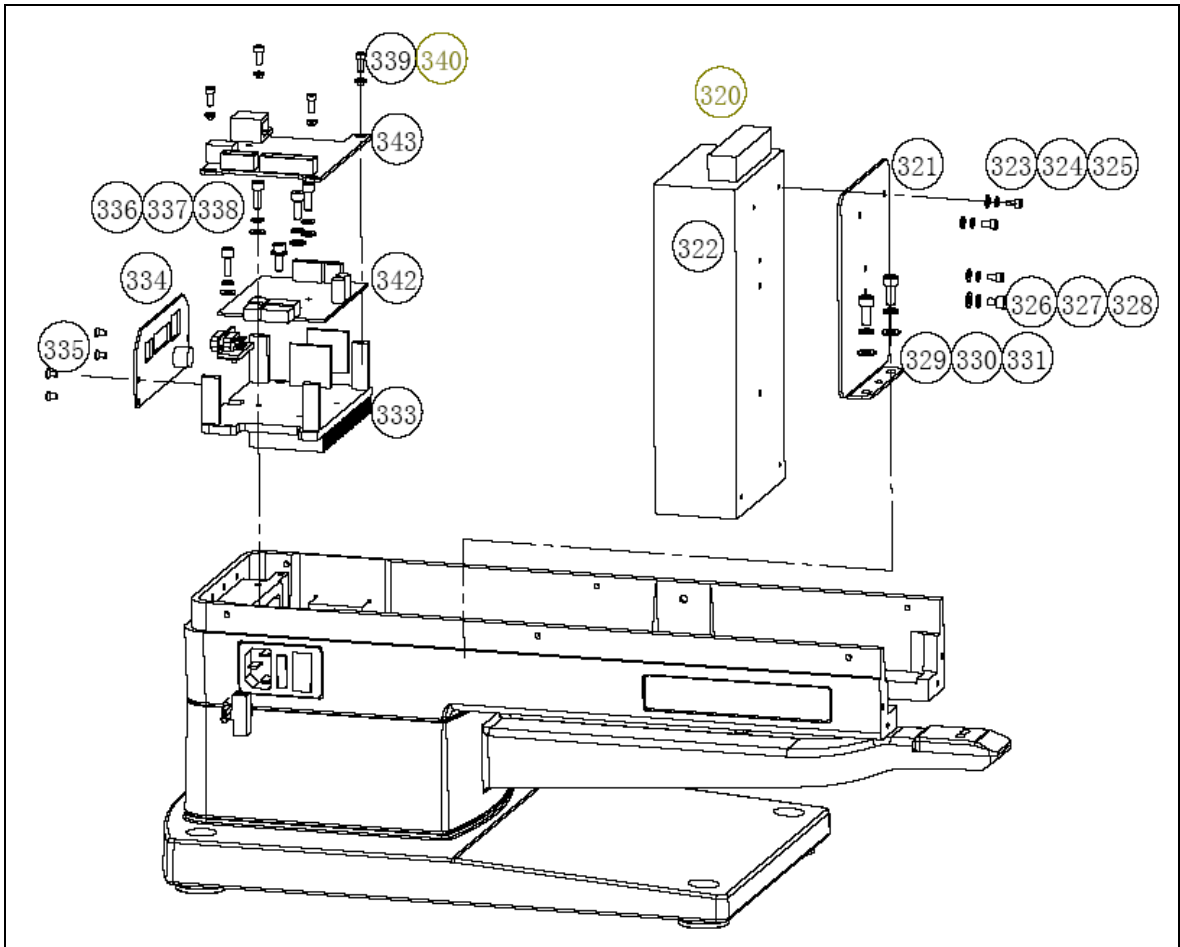

Switch Power Supply Assy. and Driver Assy. Spare Part List

Item	P/N	Description	Qty.
321	3-05-0051-01	Bracket, Power	1
322	130036006201	Power Supply, Switching	1
323	140001000802	Screw, Hexagon Socket Cup Head, Black 3X6	3
324	140012007901	Lock Washer, Black D3	3
325	140012012201	Washer, Black D3	3
326	140001057601	Screw, Hexagon Socket Cup Head, Black 4X6	1
327	140012012101	Washer, Black D4	1
328	140012008001	Lock Washer, Black D4	1
329	140001057801	Screw, Hexagon Socket Cup Head, Black 5X12	2
330	140012015801	Washer, Black D5	2
331	140012010601	Lock Washer, Black D5	2
333	3-05-0052-01	Holder, Driver	1
334	3-06-0042-01	Assy, Rear Panel	1
335	140003005302	Screw, Hexagon Socket Countersunk Head, Black 3X6	4
336	140001057401	Screw, Hexagon Socket Cup Head, Black 4X12	3
337	140012012101	Washer, Black D4	3
338	140012008001	Lock Washer, Black D4	3
339	140001001002	Screw, Hexagon Socket Cup Head, Black 3X8	4
340	130907001101	Dielectric, washer	4
342	130306006401	Driver, Step Motor	1
343	630ESC0108	Controller, Step Motor, Ethernet	1

Cover R & L Assy. Exploded Illustration:

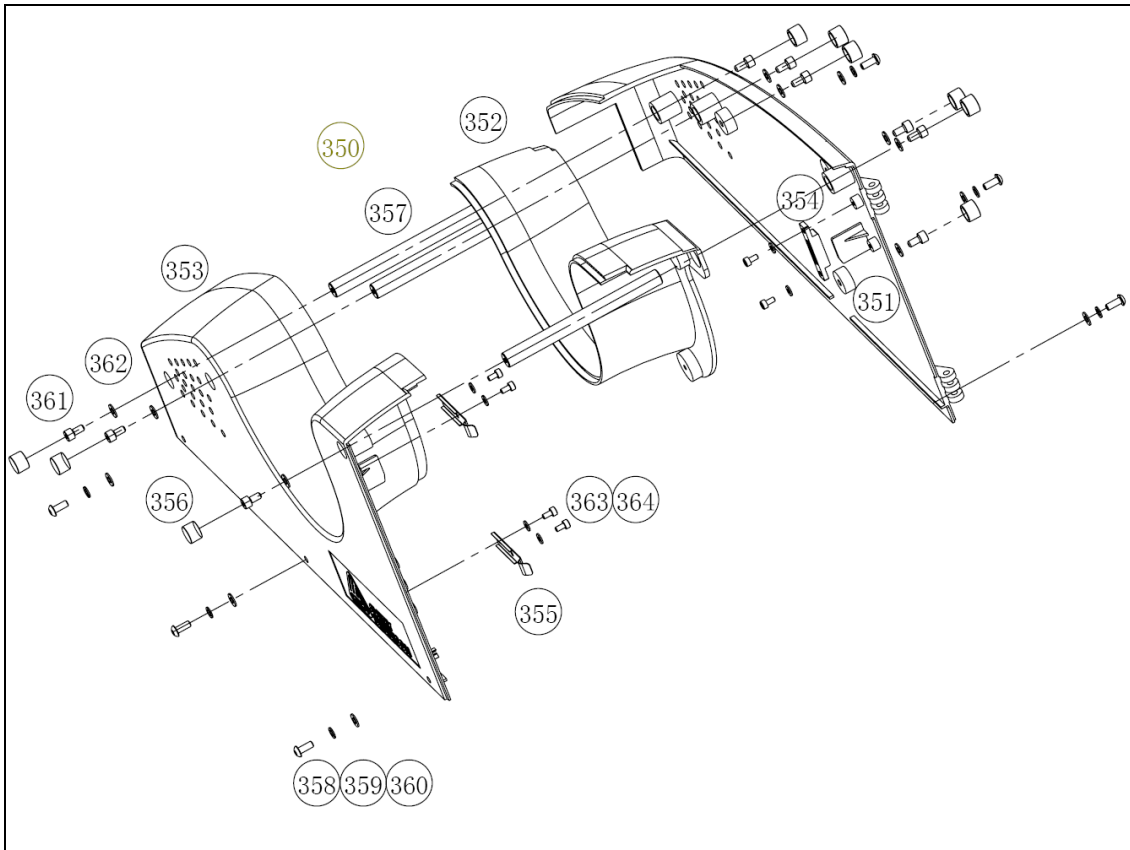

Cover R & L Assy. Spare Part List:

Item	P/N	Description	Qty.
350	3-06-0027-01	Assy, Cover R & L	1
351	3-05-0055-01	Cover, Left	1
352	3-05-0056-01	Cover, Top	1
353	3-05-0057-01	Cover, Right	1
354	3-05-0058-01	Board, Wire	1
355	DT0018-001	Spring, Front Door	2
356	3-05-0088-01	Cover, Screw	9
357	3-05-0085-01	Shaft, Cover	3
358	140002010501	Screw, Hexagon Socket Half-Round Head, Stainless Steel 4X10	6
359	140012012601	Lock Washer, D4	6
360	140012000302	Washer, D4	6
361	140001057701	Screw, Hexagon Socket Cup Head, Black 4X8	9
362	140012012101	Washer, Black D4	9
363	140001000802	Screw, Hexagon Socket Cup Head, Black 3X6	6
364	140012012201	Washer, Black D3	6

Door Enclosure Assy. Exploded Illustration:

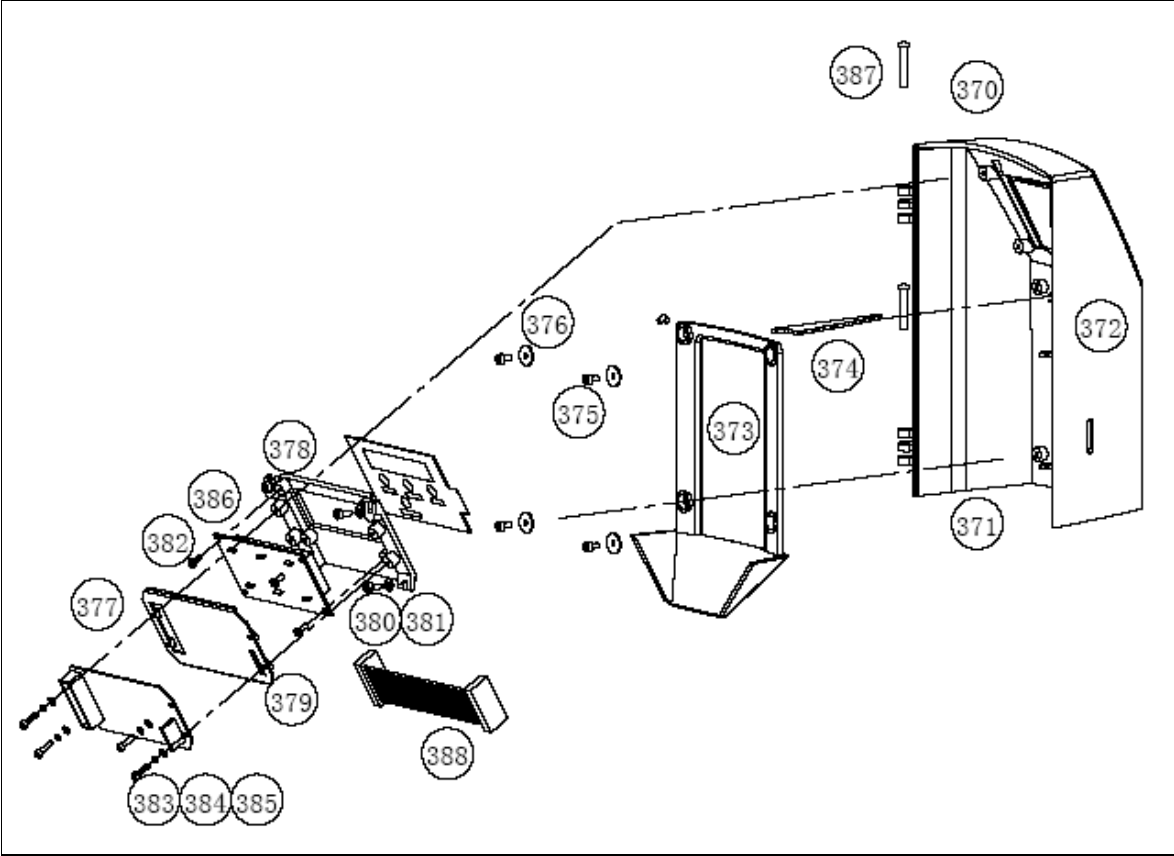

Door Enclosure Assy. Spare Part List:

Item	P/N	Description	Qty.
370	3-06-0028-01	Assy, Door Enclosure	1
371	3-06-0029-01	Assy, Cover, Front	1
372	3-05-0059-01	Cover, Front	1
373	3-05-0060-01	Door, Needle Guard	1
374	3-05-0084-01	Piece, Front Door	1
375	140001000802	Screw, Hexagon Socket Cup Head, Black 3X6	4
376	DT0028-001	Washer, 3X12	4
377	3-06-0030-01	Assy, Panel	1
378	3-05-0061-01	Board, Support	1
379	3-05-0090-01	Cover, PCB	1
380	140001001002	Screw, Hexagon Socket Cup Head, Black 3X8	4
381	140012012201	Washer, Black D3	4
382	140002013401	Screw, Half-Round Crossed Head, Stainless Steel 2.5X6	4
383	140001052001	Screw, Hexagon Socket Cup Head, Stainless Steel 2.5X10	4
384	140012016201	Lock Washer, D2.5	4
385	140012016301	Washer, D2.5	4
386	3-06-0031-01	Assy, LCD	1
387	140010000501	Rivet, Aluminum Φ 4X24	2
388	3-06-0032-01-1	Assy, Panel Wires	1

Contact Information

AMERICAS

UNITED STATES

Avery Dennison Corporation
Fastener Division
224 Industrial Road
Fitchburg, MA 01420
Tel: 800-225-5913
Fax: 800-848-2169
Email: fastener.usa@averydennison.com

MEXICO

Avery Dennison de Mexico
Aristoteles #123
Parque Industrial Kalos
Apodaca, Nuevo Leon
66600 Mexico
Phone: 52 (81) 8864-4100
Fax: 52 (81) 8864-4101
Email: fastener.mexico@averydennison.com

BRAZIL

Avery Dennison do Brasil Ltda.
Rua Francisco Foga, 225
CP 18 – CEP 13280-000
Vinhedo-SP, Brasil
Tel: 55-19-3876-7696 / 0800-7010076
Fax: 55-19-3876-6763
Email: fastener.brazil@averydennison.com

EUROPE, MIDDLE EAST, AFRICA

UNITED KINGDOM

Avery Dennison Fastener Europe
14-16 Thomas Road
Wooburn Industrial Park
Wooburn Green
Bucks HP10 0PE
United Kingdom
Tel: 44 (0) 1628 859500
Fax: 44 (0) 1628 859567
Email: fastenersalesuk@eu.averydennison.com

Visit us on the web at
www.fastener.averydennison.com

ASIA

HONG KONG

Avery Dennison (HK) Ltd.
1/F., No. 7 Chun Ying Street
Tseung Kwan O Industrial Estate
NEW TERRITORIES
Hong Kong
Phone: 852-2555-9441
Fax: 852-2873-6436
Email: info_fap@ap.averydennison.com

JAPAN-TOKYO

Tokyo Office
Avery Dennison Overseas Corporation
6-47-8 Fujimi-Cho
Tachikawa-City, Tokyo 190-0013
Japan
Phone: 81-42-526-7310
Fax: 81-42- 526-7315
Email: info_fap@ap.averydennison.com

JAPAN-OSAKA

Avery Dennison Overseas Corporation
Shin-Osaka Ikushima Bldg, 7F
5-1-3 Miyahara, Yodogawa-ku
Osaka-City, Osaka 532-0003
Japan
Phone: 81-6-397-7451
Fax: 81-6-397-7453
Email: info_fap@ap.averydennison.com

KOREA

Avery Dennison Korea Ltd.
872, Kwan Yang 2-Dong, DongAn-Ku
AnYang-Si, Kyounggi-Do
Korea 431-062
Phone: 82-31-425-6140
Fax: 82-31-425-6145
Email: info_fap@ap.averydennison.com

Visit us on the web at
www.fastener.averydennison.com